



Installation Instructions for TLC80RAX Toyota Landcruiser 80 Series 160lt Auxiliary Fuel Tank

This auxiliary tank fits up under the rear of factory single tank 80 Series Landcruiser.

Fuel is transferred via an electric pump that will pump fuel from the auxiliary tank into the OEM tank. A combination switch/gauge will be located into a suitable position in the dash. When the switch is in operation an ORANGE light will be ON, indicating that the transfer pump is in operation. A series of lights will also indicate fuel level. All GREEN lights on showing FULL, one RED flashing light showing EMPTY.

Once empty the pump will automatically shut off after 2 minutes.

1. Remove spare wheel carrier (if applicable).
2. Remove rounded sheet metal bracket from the front of the RHS floor stiffening rib (if applicable).
3. Carry out installation of wiring component as per wiring diagram. And mount the fuel transfer pump to the vehicle chassis
4. Bolt the new front and rear tank mounting brackets to the chassis and secure.
**Some early 80 Series did not have the four (4) cage nuts in the front cross member, to enable mounting front bracket. If necessary refer to installation diagram for hole positions and drill holes as required.
5. Cut the original filler neck pipe directly in line with the inside of the chassis rail. NOTE: WHEN CUTTING FILL NECK DO NOT USE TOOL THAT WILL CREATE SPARKS OR FLAMES.
6. Install new twin filler neck. Connect all remaining hoses and fittings as per diagram.
7. Check for clearance from body and chassis, fill with fuel and check for leaks.



FITTING KIT CONTENTS TLC80RAX

Brass: <ul style="list-style-type: none"> ○ 2 x P6 1/2 x 1/4 Elbow ○ 1 x P3 5/16 x 1/4 Straight ○ 1 x P3 1/2 x 1/4 Straight ○ 1 x 1/4 BSP Plug ○ 1 x 12mm x 8mm Reducing Tee 	Electrical: <ul style="list-style-type: none"> ○ 1 x LRAPG210 Combination Switch/Gauge ○ 1 x 3mm 2 Core Wire @ 6m Long ○ 1 x 4mm Single Core Red Wire @500mm ○ 1 x 4mm Single Core Blue Wire @300mm ○ 1 x 5AMP Fuse ○ 1 x Fuse Holder ○ 2 x Fuse Holder Terminals ○ 4 x Red Insulated Terminals ○ 1 x Red Eye Terminal ○ 1 x 8mm Blue Eye Terminal ○ 2 x Red Male Terminals
Bolts / Nuts: <ul style="list-style-type: none"> ○ 12 x M8 x 25 bolts ○ 2 x M12 x 30 bolts ○ 12 x M8 flat washers ○ 12 x M8 spring washers ○ 2 x M10 flat washers ○ 2 x M10 Nyloc nuts ○ 2 x M12 Nyloc nuts ○ 4 x M12 flat washers ○ 1 x Tek screw 	Misc Parts: <ul style="list-style-type: none"> ○ 1 x 80 Series Twin Filler ○ 1 x Rear Mounting Bar ○ 1 x Front Mounting Bracket
Hose Clamps: <ul style="list-style-type: none"> ○ 6 x 1/4" hose clamps ○ 6 x 1/2" hose clamps ○ 4 x 1 1/2" hose clamps 	Hose: <ul style="list-style-type: none"> ○ 1 x 8mm hose 1200mm long ○ 2 x 12mm hose 600mm long ○ 2 x 44mm hose 155mm long
Pumps & Filters: <ul style="list-style-type: none"> ○ 1x Fuel Transfer Pump & Filter ○ 1 x Fuel Pump Mounting Plate 	Cable Ties: <ul style="list-style-type: none"> ○ 10 x 7" cable ties ○ 5 x 11" cable ties

Sender:	6 Pages of Fitting Instructions consisting of:
<ul style="list-style-type: none">○ 1 x 0-90 OHM Sender Unit C/W 500mm Earth, Installed Using:<ul style="list-style-type: none">- 5 x M5 x 10mm Pan Heads- 5 x M5 Spring Washers	<ul style="list-style-type: none">○ 1 x Page Fitting Instructions○ 2 x Page Fitting Kit Contents○ 2 x Installation Diagram○ 1 x WDSGPG210

Kit Packed By _____

Checked By _____

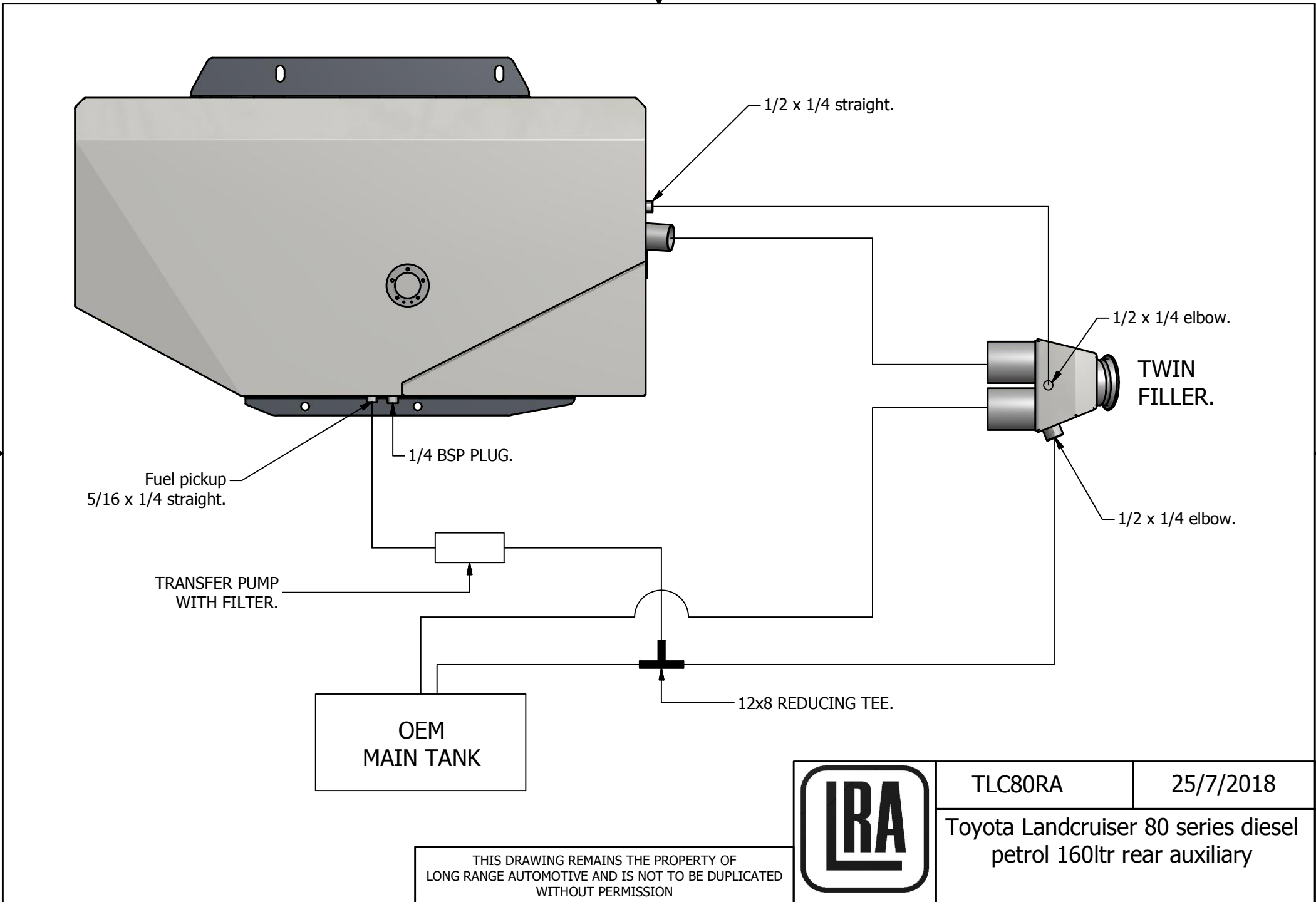

80 Series landcruiser.
with no captive nuts in crossmember.

Section of L/H
chassis rail.

NOTE:
Drill 4x Ø8.5 holes

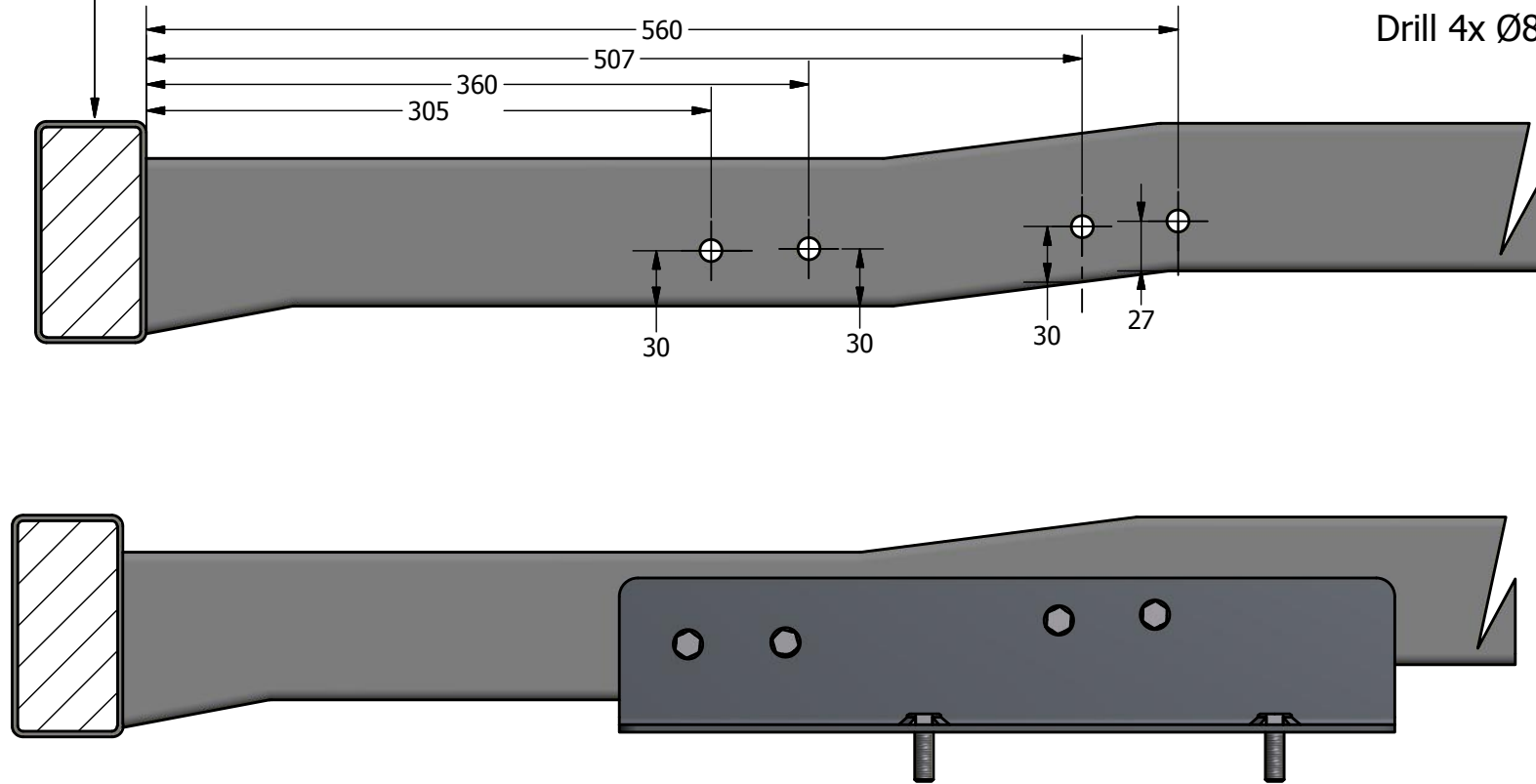

THIS DRAWING REMAINS THE PROPERTY OF
LONG RANGE AUTOMOTIVE AND IS NOT TO BE DUPLICATED
WITHOUT PERMISSION



TLC80RR/RAX

25/07/2018

Toyota Landcruiser 80 series
rear replacement / auxillary tank.
Crossmember drilling location.

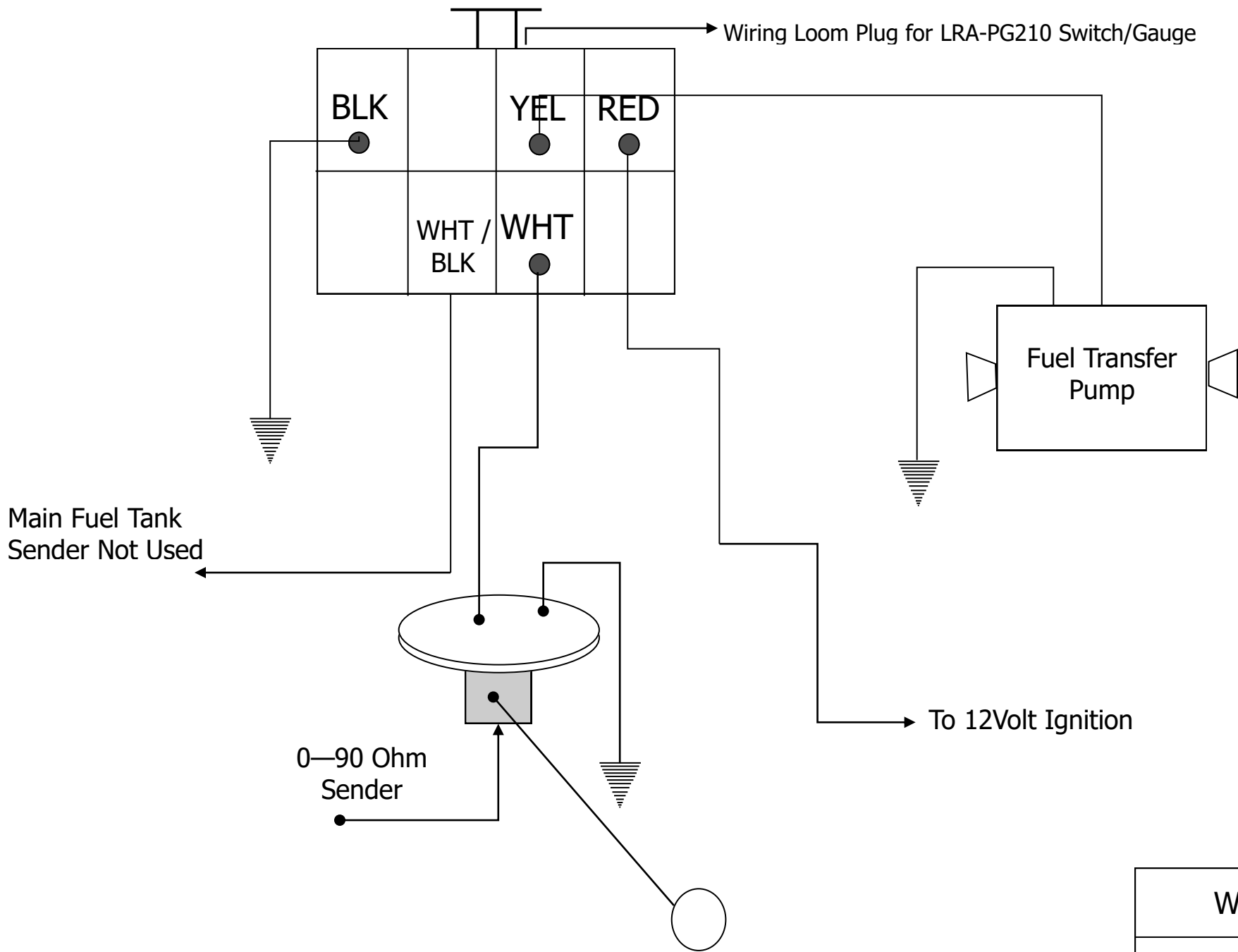

WDSGPG210