



Installation Instructions for JGCHPWH Jeep Grand Cherokee WH Petrol 110L Auxiliary Tank

This auxiliary tank fits under the rear of the vehicle and takes the place of the spare wheel. Fuel is transferred via an electric pump that will pump fuel from the auxiliary tank into the OEM tank. A combination switch/gauge will be located into a suitable position in the dash. When the switch is in operation an ORANGE light will be ON, indicating that the transfer pump is in operation. A series of lights will also indicate fuel level. All GREEN lights on showing FULL, one RED flashing light showing EMPTY.

(DO NOT OPERATE TRANSFER PUMP WITH NO FUEL IN AUXILIARY TANK OR PUMP FAILURE WILL OCCUR).

1. Select a suitable location in the dash to mount the switch gauge unit. A 12V ignition source can be found under the dash to the left of the steering column; Blue 4mm wire. Carry out wiring and run the twin core to the rear of the vehicle for connection to fuel transfer pump and sender unit.
2. Remove the spare wheel and unbolt the wheel winding mechanism.
3. Bolt the front and rear secondary brackets in place. The front bracket fits on the front face of the crossmember that is just behind the differential. There are 3 holes to line up and the one on the RHS will need to be drilled out to 10.5mm. Use the M10 x 30 bolt with the straps attached to fix in place with washers and Nyloc nuts. To bolt the rear bar in place you will need to locate the 16mm holes on the inside of the rear chassis section and drill a hole 12.5mm diameter to the outside of this member. Use the 2 different length tube spacers and the M12 x 50mm & 60mm bolts, washers and Nyloc nuts to secure member in place.
4. On the LHS box section chassis rail unclip the wiring from the member and using the wiring clip hole as reference, hole saw a 38mm diameter hole at this point. This will be for the fast fill vent hose to pass through. Use the two canister re-location brackets to move the emission canister backwards to make room for the auxiliary tank filler.

5. Remove the STD filler neck together with the rigid plastic fast fill line. Prepare the new twin filler and fill pipe for installation. The P6 5/8 x 3/8 elbow goes in the neck pointing in the same direction as the fill pipe. P6 5/16 x 1/8 elbow goes in the top of the twin filler neck. P6 5/16 x 1/4 elbow goes in the main tank fill pipe pointing forward. Remove the rigid plastic fast fill from the original neck and fit to the new neck. Fit the assembly back into the vehicle and connect main tank fill pipe to original hose and to the twin filler with 32mm hose. (If you are fitting this tank to a Jeep Commander you will have to cut some length from the OE fill hose).
6. Mount the fuel pump in a suitable protected location to the floor pan in the area above the main tank fill pipe. Check to ensure no part of the suspension can make contact with the pump. Connect the pump outlet to the 5/16 elbow in the main tank fill pipe. Complete wiring of the pump.
7. Lift tank into position (remembering to connect sender unit) and secure with M10x30mm bolts, Nyloc nuts and washers. Complete remaining hose connections; 8mm fuel pick-up to inlet side of pump with inline filter. 16mm hose from twin filler to auxiliary tank (through hole previously cut in rail). Use CF20 corrugated tubing to protect this hose going through the rail. Use the 38mm diameter fill pipe bend and the 2 x 38mm hose @ 100mm long to connect auxiliary branch of twin filler to the auxiliary tank. Connect sender unit earth.
8. Check over all clearances and neatly cable tie all hoses and wiring. Fill with fuel and check transfer pump operation.



FITTING KIT CONTENTS JGCHPWH

Brass: <ul style="list-style-type: none"> ○ 1 x P6 5/16 x 1/8 elbow ○ 1 x P3 5/16 x 1/4 straight ○ 1 x P6 5/16 x 1/4 elbow ○ 1 x P3 5/8 x 3/8 straight ○ 1 x P6 5/8 x 3/8 elbow 	Electrical: <ul style="list-style-type: none"> ○ 1 x LRA-PG210 switch/gauge unit ○ 1 x 3mm two core @ 7000mm ○ 1 x 4mm Single Core Blue @ 300mm ○ 1 x 5 AMP Fuse ○ 1 x Fuse Holder ○ 2 x Fuse Holder Terminals ○ 1 x red terminal ○ 2 x red eye terminals ○ 1 x blue eye terminals – 6mm ○ 3 x heat shrink @ 30mm
Bolts / Nuts: <ul style="list-style-type: none"> ○ 2 x TEK screws ○ 4 x M10 x 30 bolts ○ 2 x M12 x 50 bolts ○ 2 x M12 x 60 bolts ○ 4 x M12 x 30 flat washers ○ 12 x M10 x 25 flat washers ○ 2 x M10 spring washers ○ 4 x M12 Nyloc nuts ○ 5 x M10 Nyloc nuts ○ 1 x M6 nuts (dash earth) 	Misc Parts: <ul style="list-style-type: none"> ○ 1 x Twin Filler – Petrol Type #TFJGCHPWH ○ 1 x Fill Pipe Main #FPJGCHTDWH1 ○ 1 x Fill Pipe Auxiliary #FPJGCHTDWH2 ○ 2 x canister re-locate brackets ○ 2 x 16mm OD tube @ 27mm ○ 2 x 16mm OD tube @ 16mm ○ 1 x front secondary bracket (2 x M10 nuts welded) ○ 1 x rear mount bar ○ 1 x fuel cap ○ 3 x M10 x 30 with 150mm strap
Hose Clamps: <ul style="list-style-type: none"> ○ 8 x 1/4 hose clamps ○ 2 x 5/8 hose clamps ○ 7 x 1 1/4 hose clamps 	Hose: <ul style="list-style-type: none"> ○ 1 x 8mm hose @ 1200mm ○ 1 x 8mm hose @ 1000mm ○ 1 x 32mm hose @ 100mm ○ 2 x 38mm hose @ 100mm ○ 1 x 16mm NTP hose @ 560mm ○ 1 x CF20 @ 150mm

Pumps & Filters:	Cable Ties:
<ul style="list-style-type: none"> ○ 1 x Fuel Pump & Filter ○ 1 x fuel pump mounting bracket 	<ul style="list-style-type: none"> ○ 15 x 7" cable ties
Sender:	5 Pages of Fitting Instructions Consisting of:
<ul style="list-style-type: none"> ○ 1 x 0-90 OHM sender C/W with 500mm earth, Installed Using: <ul style="list-style-type: none"> - 5 x M5 x 10 Pan Head Screws - 5 x M5 Spring Washers 	<ul style="list-style-type: none"> ○ 2 x pages fitting instructions ○ 2 x page fitting kit contents ○ 1 x page wiring diagram – WDSPG210

Kit Packed By _____

Checked By _____

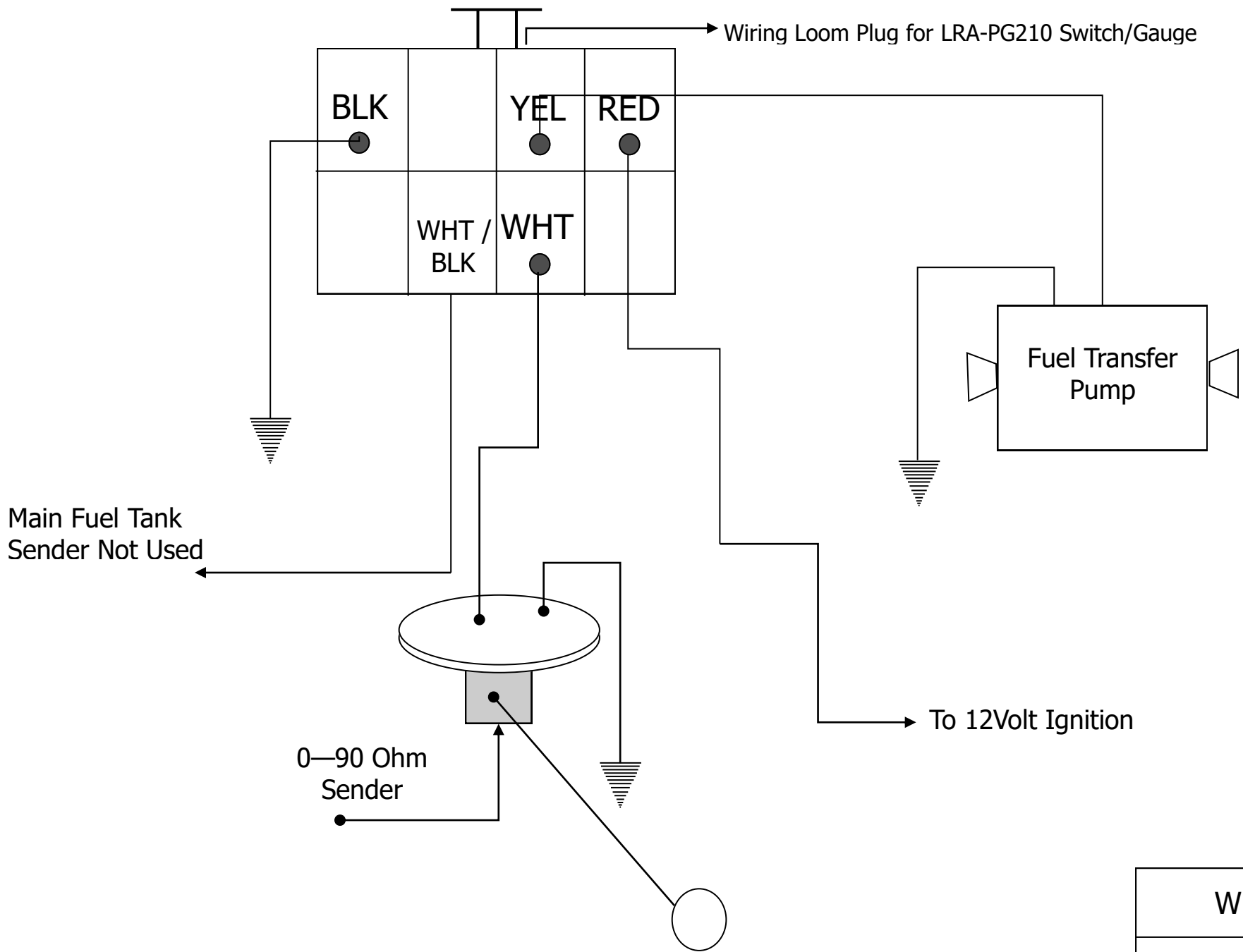

WDSGPG210