



Installation Instructions for JGCHWKDA Jeep Grand Cherokee WK Diesel 75lt Auxiliary Tank

This Auxiliary tank fits under the rear of the vehicle.

Fuel is transferred via an electric pump that will transfer fuel from the auxiliary tank into the OEM tank. A combination switch/gauge will be fitted in a suitable position in the dash. When the switch is in operation an ORANGE light will be ON, indicating that the transfer pump is in operation. A series of lights will also indicate the fuel level. All GREEN lights showing FULL, one RED flashing light showing EMPTY.

(DO NOT OPERATE TRANSFER PUMP WITH NO FUEL IN AUXILIARY TANK OR PUMP FAILURE WILL OCCUR).

1. Select a suitable location for the switch/gauge unit. We suggest mounting it in the small flat section just forward and to the RHS of the Auto Shift (Ref Pic PG200). A 12volt ignition power source can be found under the end cover of the RHS of the dash. (Pink wire with a Green trace). Carry out wiring of switch gauge unit and run the twin core cable under the scuff plates and to the rear of the vehicle. Remove the spare wheel and trim cover, lift the carpet to gain access to the floor. Drill 8mm hole on the LHS of the spare wheel well as per Fig 1 and run the twin core through the grommet and out this hole.
2. Remove the LHR wheel and wheel arch cover. Clamp the fill hose and unbolt the filler neck assembly. Cut the filler neck pipe and fast fill vent pipe as shown in Fig 2, make sure the cuts are filed smooth so there are no sharp edges and the pipe is round and not out of shape. Screw the fittings into the new twin filler neck as per Fig. Remove the vent end cap from the original filler and fit to the new twin filler. Refit to vehicle using the 70mm length of 32mm hose to join the original fill pipe to the new twin filler. You will need to carefully bend the 8mm vent tube to connect it back to the 8mm hose from the vent end cap. Mount the Fuel transfer pump in the wheel arch as per Fig 4.
3. Loosen the L/H muffler and remove and discard the tow hook bracket and brace from the LHS, use the M12 fine thread nut to secure the one bolt from the brace

that cannot be removed. Bolt the LH and RH secondary brackets in place using the tow bar bolts or the OE bolts (If no tow bar fitted) as per Fig 5. If the wiring for the trailer plug comes out of one of the plastic bungs in the floor you will need to trim the bung so the wiring can sit snugly to the floor. Remove the two metal studs from the LHS of the floor pan. Screw the fittings into the tank as per Fig 6.

4. Using the floor reinforcing plate as a template, from the inside of the wheel well drill the two 10.5mm holes for the front mount. Note, there are two holes in the RHS of the floor plate and the tank. Check if the corresponding holes in the underside of the vehicle are 190mm apart or 210mm and drill the appropriate holes. (YOU WILL NEED TO TRIM THE BODY DEADENER AWAY FROM WHERE THE FLOOR PLATE SITS as per Fig 7. Lift the tank into position and fit the 16mm x 50mm crush tubes on top of front mount as the tank goes into position. Don't forget to connect the sender unit wire and ensure that the wiring is not pinched on the top of the tank. Secure tank with M10 x 80mm bolts washers and Nyloc nuts.
5. Connect the auxiliary tank filler with the 2 x 90mm lengths of 32mm hose and the metal fill pipe. Connect the OE fast fill vent tube to the P6 5/8 x 3/8 elbow on the twin filler with the 400mm length of 16mm NTP hose. Connect the 1100mm length of 12mm hose from the auxiliary tank to the P6 1/2 x 3/8 elbow on the twin filler. Connect the fuel filter to the fuel pickup on the auxiliary tank with the 150mm length of 8mm hose and use the 1200mm length of 8mm hose to connect the filter to the inlet side of the pump. Use the 400mm length of 8mm hose to connect the outlet side of the pump to the P6 5/16 x 1/8 elbow on the twin filler. Fit CF 20 and CF16 Conduflex to the pickup and fast fill lines to protect them where they are exposed in the wheel arch. Secure the fill pipe and fuel lines with P Clips and TEK screws as shown in Fig 4. Secure the sender unit earth wire to the body. Neatly cable tie all hoses and wiring in place. Check transfer pump operation. Refit wheel arch cover and refit spare wheel trim etc.



JGCHWKDA
FIGURE 1

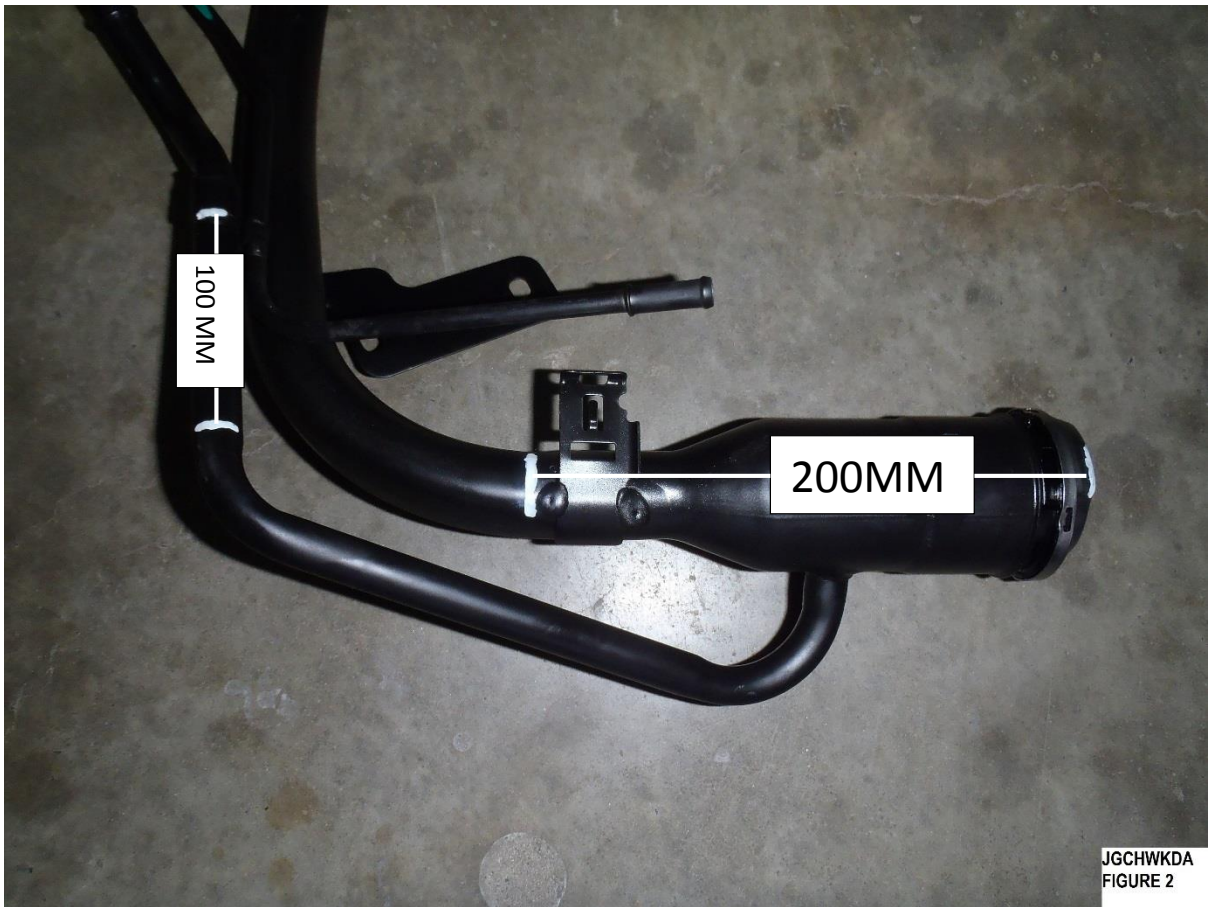

JGCHWKDA
FIGURE 2

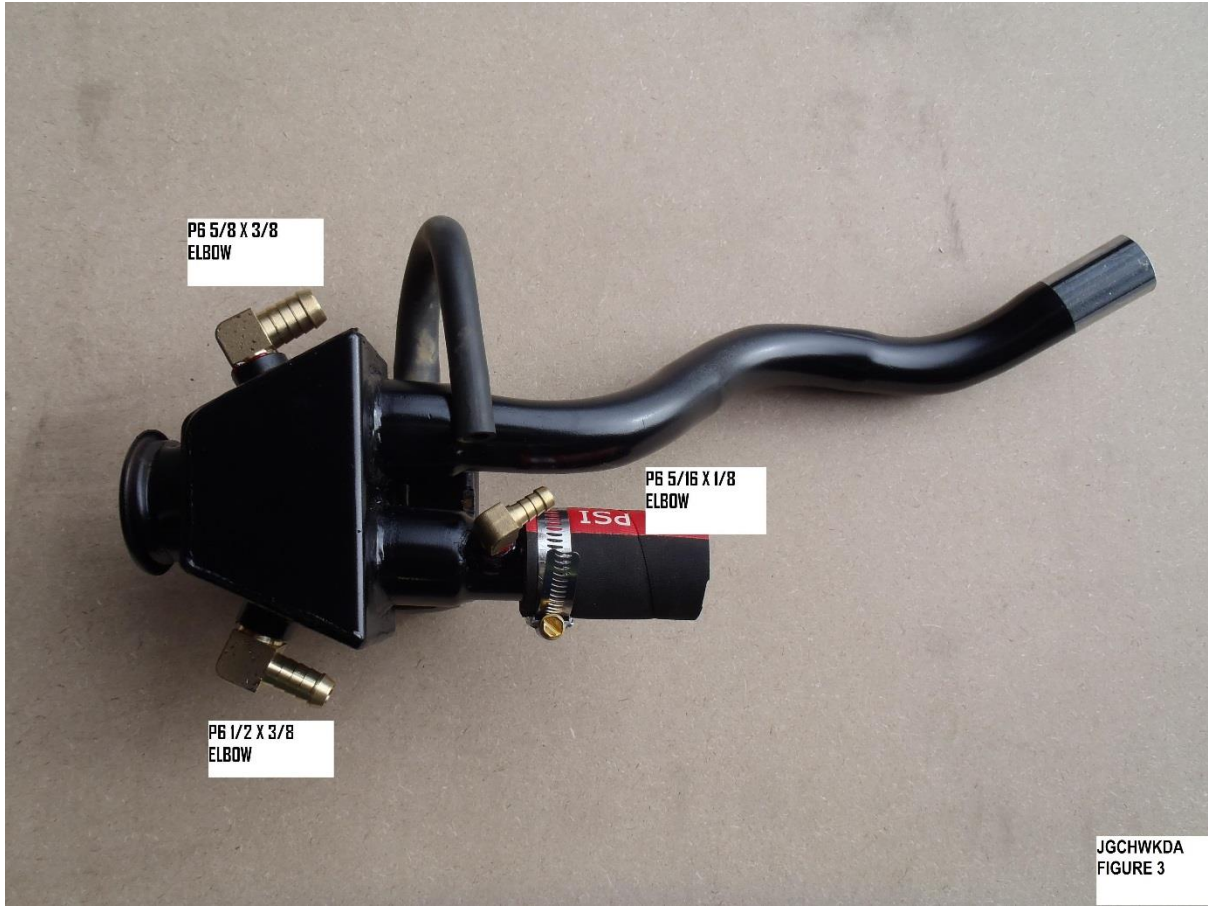



JGCHWKDA
FIGURE 5



P6 5/16 X 1/4
ELBOW

P3 1/2 X 3/8
STRAIGHT

JGCHWKDA
FIGURE 6

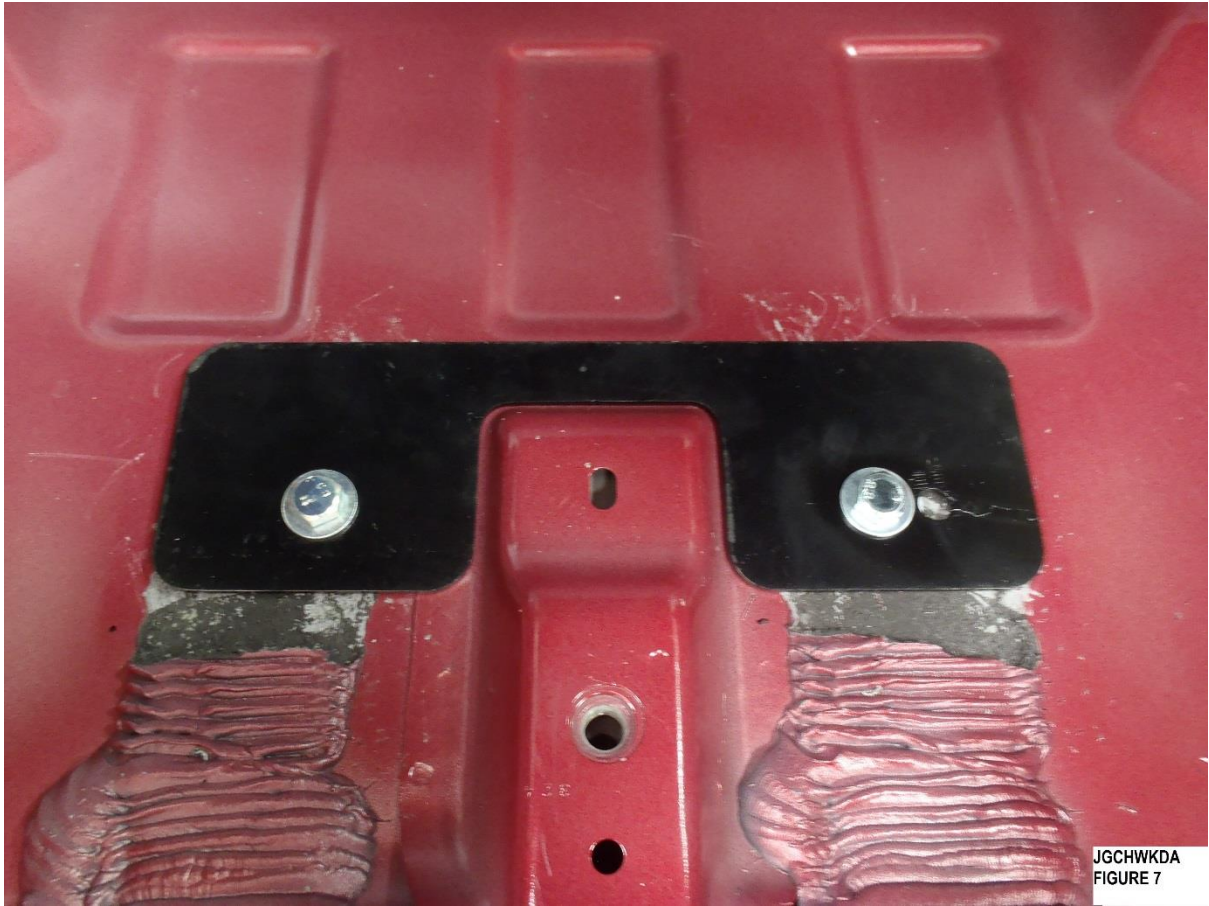

JGCHWKDA
FIGURE 7



JGCHWK-PG200

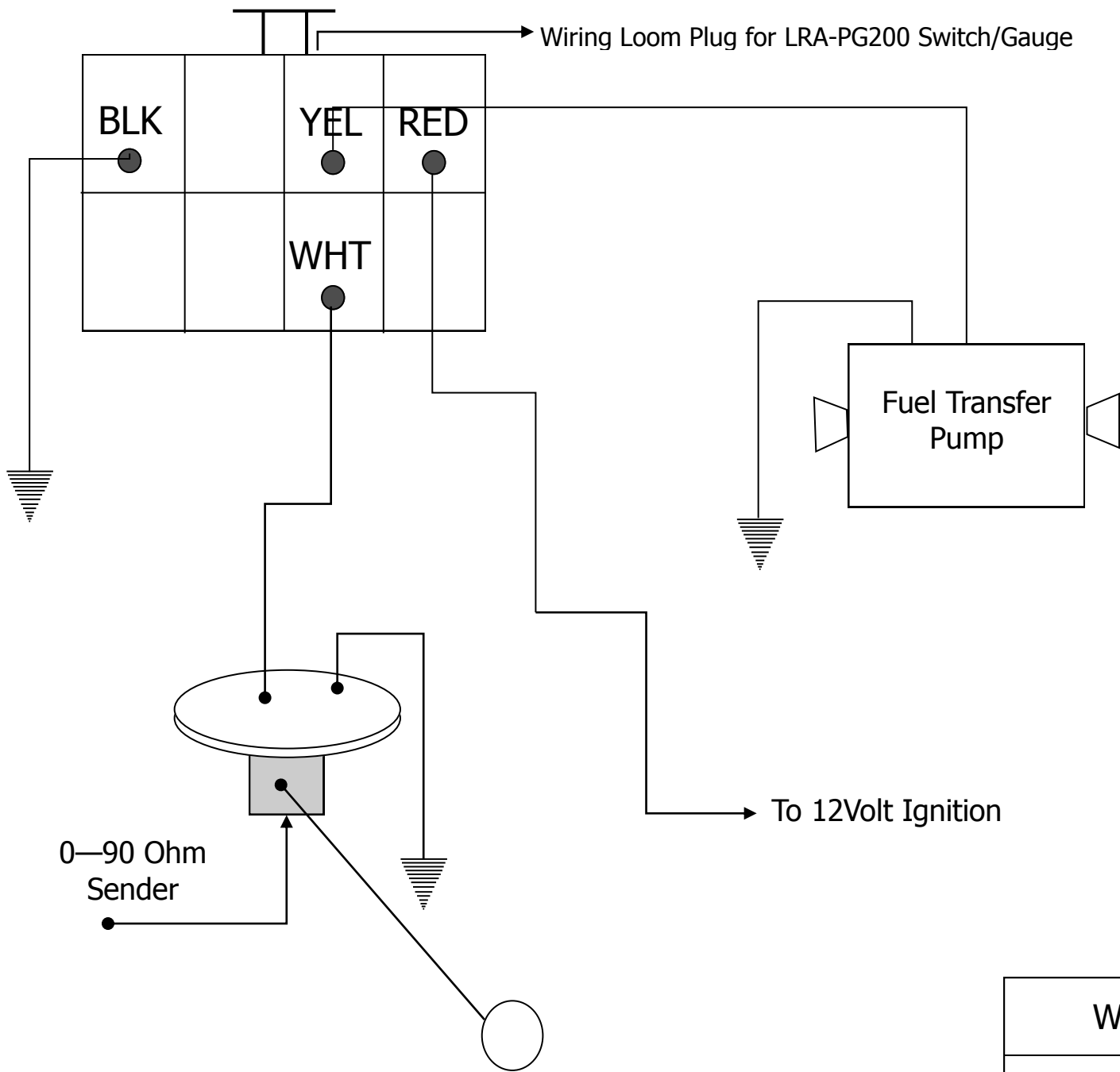

WDSGPG200



FITTING KIT CONTENTS JGCHWKDA

Brass <ul style="list-style-type: none"> ○ 1 x P6 5/16 x 1/8 Elbow ○ 1 x P6 5/16 x 1/4 Elbow ○ 1 x P3 1/2 x 3/8 Straight ○ 1 x P6 1/2 x 3/8 Elbow ○ 1 x P6 5/8 x 3/8 Elbow 	Electrical <ul style="list-style-type: none"> ○ 1 x LRA-PG200 Switch/Gauge Unit ○ 1 x 3mm Two Core @ 7000mm ○ 1 x 3/16 x 5/16 Wiring Grommet ○ 1 x Red Insulated Terminal ○ 3 x Red Earth Eye ○ 3 x 3mm Shrink Tube @ 30mm
Bolts / Nuts <ul style="list-style-type: none"> ○ 2 x M10 x 80mm Bolts ○ 8 x M10 x 25mm Washers ○ 6 x M10 Nyloc Nuts ○ 1 x M12 Fine thread Plain Nut ○ 4 x TEK Screws ○ 2 x 25mm TEK Screws (For Pump) 	Misc Parts <ul style="list-style-type: none"> ○ 1 x FNJGCHWKDA Twin Filler ○ 1 x Fuel Cap ○ 1 x FPJGCHWK Fill Pipe ○ 1 x Floor Plate ○ 2 x Secondary Brackets with M10 x 30 bolts welded L/H & R/H ○ 2 x 16mm x 50mm Crush Tubes
Hose Clamps <ul style="list-style-type: none"> ○ 6 x 1/4 Hose Clamp ○ 2 x 1/2 Hose Clamp ○ 2 x 5/8 Hose Clamp ○ 6 x 1 1/4 Hose Clamp ○ 1 x 25mm P Clip ○ 1 x 32mm P Clip 	Cable Ties <ul style="list-style-type: none"> ○ 5 x 7" ○ 3 x 11"
Hose <ul style="list-style-type: none"> ○ 1 x 8mm Fuel Hose @ 400mm ○ 1 x 8mm Fuel Hose @ 1350mm ○ 1 x 12mm Fuel Hose @ 1100mm ○ 1 x 16mm NTP Hose @ 400mm ○ 1 x 32mm Fuel Hose @ 70mm ○ 2 x 32mm Fuel Hose @ 90mm ○ 1 x CF16 Conduflex @ 400mm ○ 1 x CF20 Conduflex @ 400mm 	Instructions <p>8 Pages Instructions Consisting of</p> <ul style="list-style-type: none"> ○ 2 Pages fitting Instructions ○ 1 Page fitting kit contents ○ 4 Pages With Images FIG 1-7 ○ 1 Page Wiring Diagram WDSGPG200
Sender <ul style="list-style-type: none"> ○ 1 x 0-90 OHM Sender Unit C/W 700mm Earth 	Filters & Pumps <ul style="list-style-type: none"> ○ 1 x Z14K Filter ○ 1 x Fuel Pump

Kit Packed By _____

Kit Checked By _____