



## Installation Instructions for JGCHWKPA Jeep Grand Cherokee WK Petrol 75L Auxiliary Tank

This Auxiliary tank fits under the rear of the vehicle. Fuel is transferred via an electric pump that will transfer fuel from the auxiliary tank into the OEM tank. A combination switch/gauge will be fitted in a suitable position in the dash. When the switch is in operation an **ORANGE** light will be ON, indicating that the transfer pump is in operation. A series of lights will also indicate the fuel level. All **GREEN** lights showing FULL, one **RED** flashing light showing EMPTY.

(DO NOT OPERATE TRANSFR PUMP WITH NO FUEL IN AUXILIARY TANK OR PUMP FAILURE WILL OCCUR).

1. Select a suitable location for the switch/gauge unit. We suggest mounting it in the small flat section just forward and to the RHS of the auto shift. A 12volt ignition power source can be found under the end cover of the RHS of the dash. (Pink wire with a green trace). Carry out wiring of switch gauge unit and run the twin core cable under the scuff plates and to the rear of the vehicle. Remove the spare wheel and trim cover, lift the carpet to gain access to the floor. Drill 8mm hole on the LHS of the spare wheel well as per **Fig 1** and run the twin core through the grommet and out this hole.
2. Remove the LHR wheel and wheel arch cover. Clamp the fill hose and unbolt the filler neck assembly. Cut the filler neck pipe and fast fill vent pipe as shown in **Fig 2**, make sure the cuts are filed smooth so there are no sharp edges and the pipe is round and not out of shape. Screw the fittings into the new twin filler neck as per **Fig 3**. Remove the vent end cap from the original filler and fit to the new twin filler. Refit to vehicle using the 70mm length of 25mm hose to join the original fill pipe to the new twin filler. You will need to carefully bend the 8mm vent tube to connect it back to the 8mm hose from the vent end cap. Mount the Fuel transfer pump in the wheel arch as per **Fig 4**.

3. Loosen the L/H muffler and remove and discard the tow hook bracket and brace from the LHS, use the M12 fine thread nut to secure the one bolt from the brace that cannot be removed. Bolt the LH and RH secondary brackets in place using the tow bar bolts or the OE bolts (If no towbar fitted) as per **Fig 5**. If the wiring for the trailer plug comes out of one of the plastic bungs in the floor you will need to trim the bung so the wiring can sit snugly to the floor. Remove the two metal studs from the LHS of the floor pan. Screw the fittings into the tank as per **Fig 6**.
4. Using the floor reinforcing plate as a template, from the inside of the wheel well drill the two 10.5mm holes for the front mount. Note, there are two holes in the RHS of the floor plate and the tank. Check if the corresponding holes in the underside of the vehicle are 190mm apart or 210mm and drill the appropriate holes. (YOU WILL NEED TO TRIM THE BODY DEADENER AWAY FROM WHERE THE FLOOR PLATE SITS as per **Fig 7**. Lift the tank into position and fit the 16mm x 50mm crush tubes on top of front mount as the tank goes into position. Don't forget to connect the sender unit wire and ensure that the wiring is not pinched on the top of the tank. Secure tank with M10 x 80mm bolts washers and Nyloc nuts.
5. Connect the auxiliary tank filler with the 2 x 90mm lengths of 32mm hose and the metal fill pipe. Connect the 8mm OE vent tube to the P6 5/16 x 1/8 Elbow on the filler box of the twin filler with the 400mm length of 8mm fuel hose. Connect the 1100mm length of 12mm hose from the auxiliary tank to the P6 1/2 x 3/8 elbow on the twin filler. Connect the fuel filter to the fuel pick up on the auxiliary tank with the 150mm length of 8mm hose and use the 1200mm length of 8mm hose to connect the filter to the inlet side of the pump. Use the 400mm length of 8mm hose to connect the outlet side of the pump to the P6 5/16 x 1/8 elbow on the twin filler. Fit CF 20 and CF16 Conduflex to the pickup and fast fill lines to protect them where they are exposed in the wheel arch. Secure the fill pipe and fuel lines with P Clips and TEK screws as shown in **Fig 4**. Secure the sender unit earth wire to the body. Neatly cable tie all hoses and wiring in place. Check transfer pump operation. Refit wheel arch cover and refit spare wheel trim etc.



## FITTING KIT CONTENTS JGCHWKPA

<b>Brass</b> <ul style="list-style-type: none"> <li>○ 2 x P6 5/16 x 1/8 elbow</li> <li>○ 1 x P6 5/16 x ¼ elbow</li> <li>○ 1 x P3 1/2 x 3/8 straight</li> <li>○ 1 x P6 1/2 x 3/8 elbow</li> </ul>	<b>Electrical</b> <ul style="list-style-type: none"> <li>○ 1 x LRA-PG210 switch/gauge unit</li> <li>○ 1 x 3mm two core @ 7000mm</li> <li>○ 1 x 5 AMP Fuse</li> <li>○ 1 x Fuse Holder</li> <li>○ 2 x Fuse Holder Terminals</li> <li>○ 1 x 4mm Single Core Blue @ 300mm</li> <li>○ 1 x 3/16 x 5/16 wiring grommet</li> <li>○ 1 x red insulated terminal</li> <li>○ 3 x red earth eye</li> <li>○ 3 x 3mm shrink tube @ 30mm</li> </ul>
<b>Bolts / Nuts</b> <ul style="list-style-type: none"> <li>○ 2 x M10 x 80mm bolts</li> <li>○ 8 x M10 x 25mm washers</li> <li>○ 6 x M10 Nyloc nuts</li> <li>○ 1 x M12 Fine thread plain nut</li> <li>○ 4 x TEK screws</li> <li>○ 2 x 25mm TEK screws (for pump)</li> </ul>	<b>Misc Parts</b> <ul style="list-style-type: none"> <li>○ 1 x FNJGCHWKPA twin filler</li> <li>○ 1 x fuel cap</li> <li>○ 1 x FPJGCHWK fill pipe</li> <li>○ 1 x floor plate</li> <li>○ 2 x secondary brackets with M10 x 30 bolts welded LH &amp; RH</li> <li>○ 2 x 16mm x 50mm crush tubes</li> <li>○ 1 x Fuel Pump Mounting Plate</li> </ul>
<b>Hose Clamps</b> <ul style="list-style-type: none"> <li>○ 8 x 1/4 hose clamp</li> <li>○ 2 x 1/2 hose clamp</li> <li>○ 4 x 1 1/4 hose clamp</li> <li>○ 2 x 1" hose clamp</li> <li>○ 1 x 25mm P clip</li> <li>○ 1 x 32mm P clip</li> </ul>	<b>Cable Ties</b> <ul style="list-style-type: none"> <li>○ 5 x 7" Cable Ties</li> <li>○ 3 x 11" Cable Ties</li> </ul>
<b>Hose</b> <ul style="list-style-type: none"> <li>○ 1 x 8mm fuel hose @ 150mm</li> <li>○ 2 x 8mm fuel hose @ 400mm</li> <li>○ 1 x 8mm fuel hose @ 1000mm</li> <li>○ 1 x 12mm fuel hose @ 1100mm</li> <li>○ 1 x 25mm fuel hose @ 70mm</li> <li>○ 2 x 32mm fuel hose @ 90mm</li> <li>○ 1 x CF16 Conduflex @ 400mm</li> <li>○ 1 x CF20 Conduflex @ 400mm</li> </ul>	<b>9 Pages Instructions Consisting of:</b> <ul style="list-style-type: none"> <li>○ 2 Pages fitting Instructions</li> <li>○ 2 Page fitting kit contents</li> <li>○ 4 Pages With Images FIG 1-7</li> <li>○ 1 Page Wiring Diagram WDSGPG210</li> </ul>

Sender	Filters & Pumps
○ 1 x 0-90 OHM sender unit with C/W 700mm earth	○ 1 x Z14K Filter ○ 1 x Fuel Pump

Kit Packed By \_\_\_\_\_

Kit Checked By \_\_\_\_\_



JGCHWKPA  
FIGURE 1



JGCHWKDA  
FIGURE 2



JGCHWKPA  
FIGURE 3

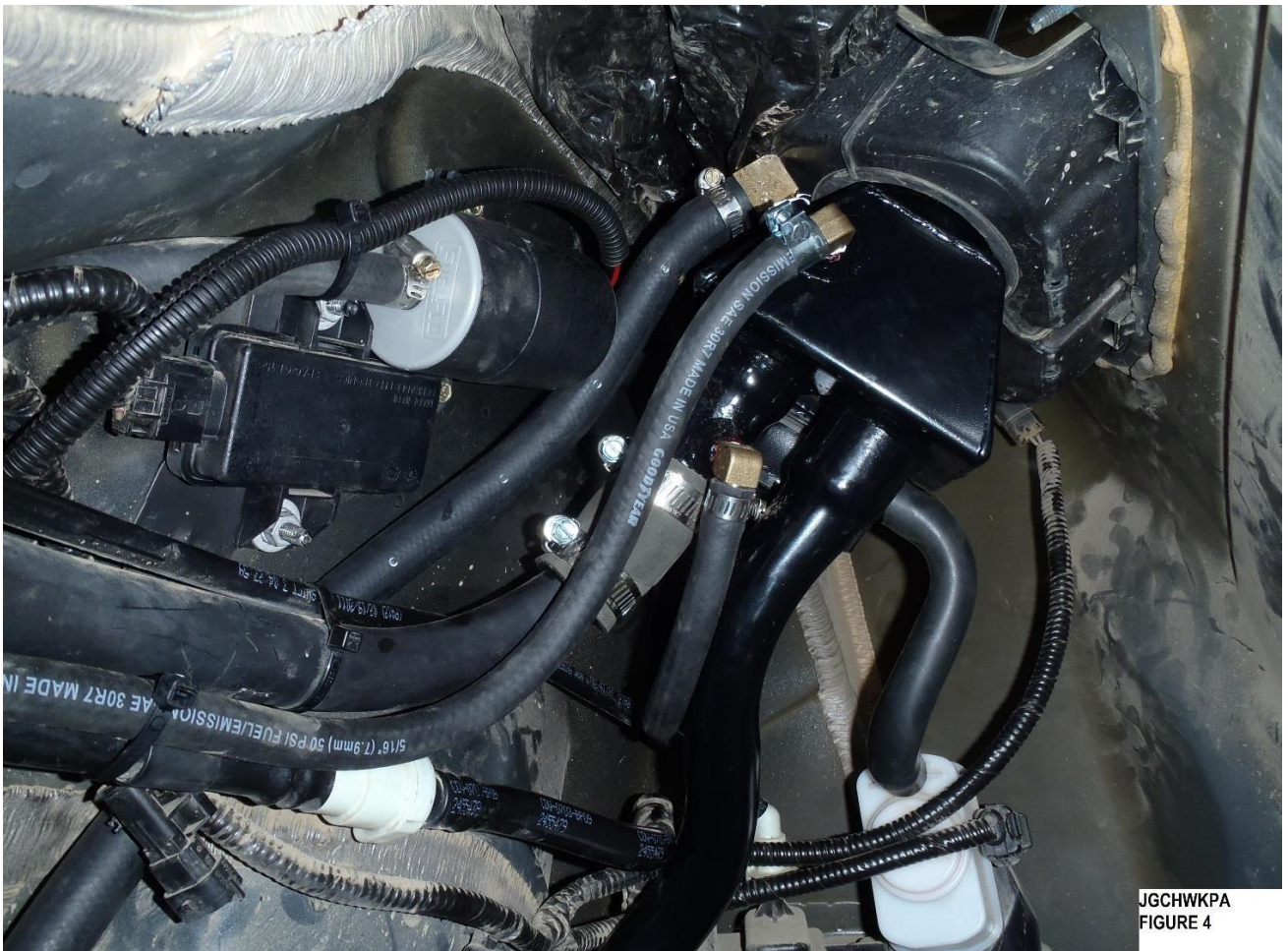

JGCHWKPA  
FIGURE 4



JGCHWKPA  
FIGURE 5



JGCHWKPA  
FIGURE 6

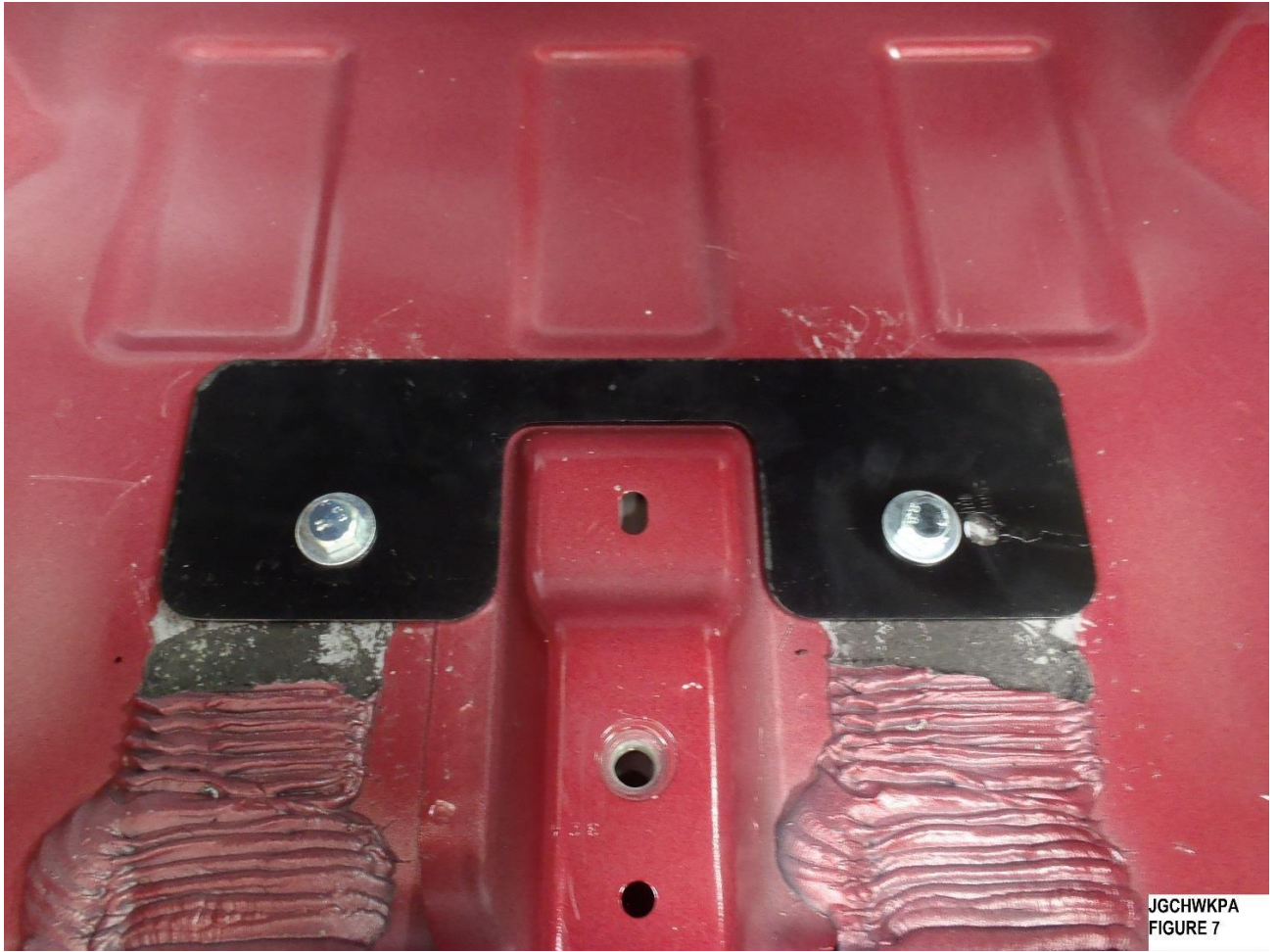

JGCHWKPA  
FIGURE 7



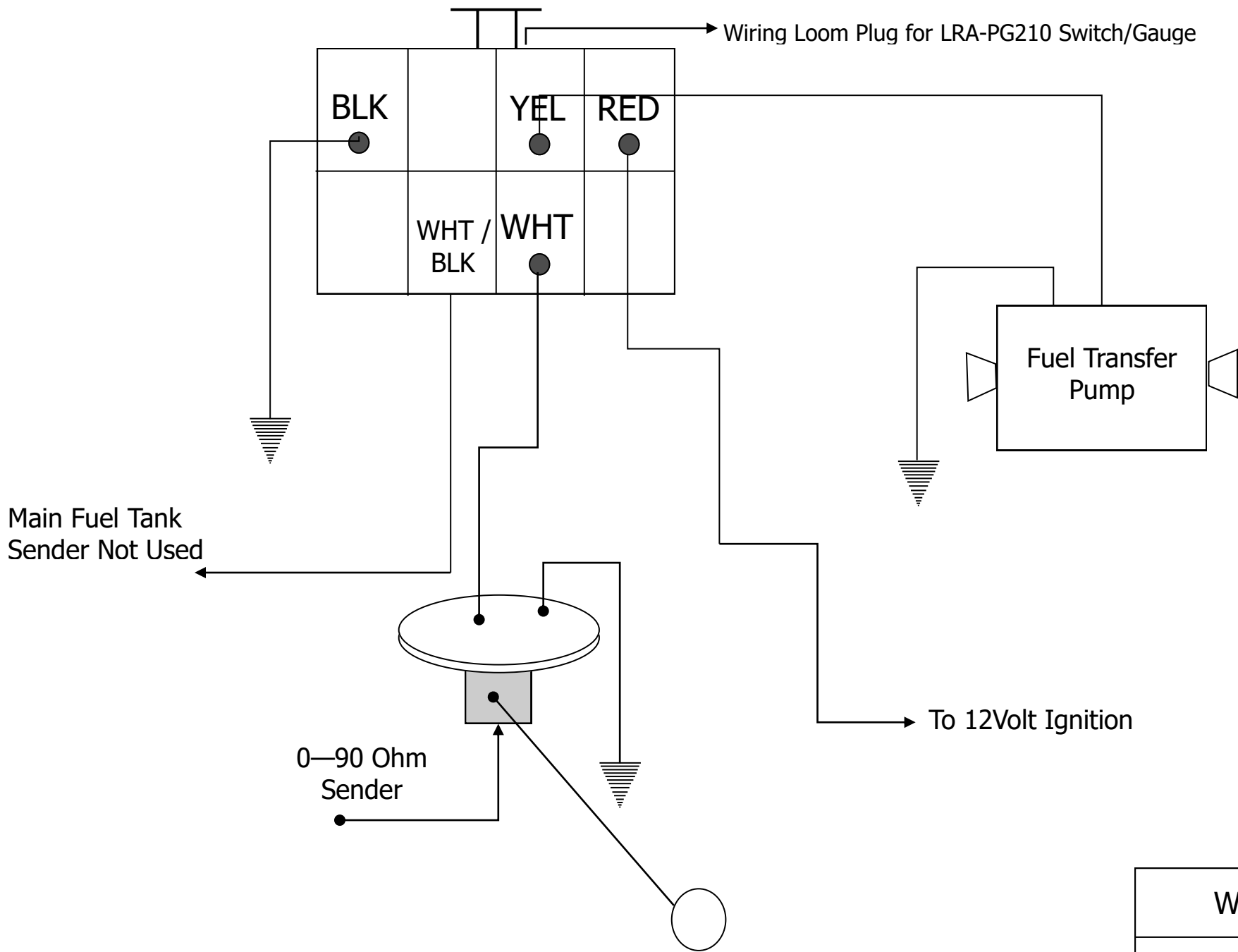

WDSGPG210