



Installation Instructions for JWJK2PA36
Jeep Wrangler JK 3.6 Pentastar
2 Door
46lt Auxiliary tank

This Auxiliary tank fits under the centre of the vehicle and comes with a replacement filler neck that will improve the filling of the main tank. Filling is via a T piece in the fill line where by the main tank will fill first and then the Auxiliary tank. (Whilst filling the main tank some fuel will always flow into the Auxiliary tank).

Fuel is transferred via an electric pump that will pump fuel from the Auxiliary tank into the OEM tank. A combination switch/gauge will be located into a suitable position in the dash. When the switch is in operation an ORANGE light will be ON, indicating that the transfer pump is in operation. A series of lights will also indicate fuel level. All GREEN lights on showing FULL, one RED flashing light showing EMPTY.

(DO NOT OPERATE TRANSFER PUMP WITH NO FUEL IN AUXILIARY TANK OR PUMP FAILURE WILL OCCUR).

1. Select a suitable location for the switch gauge unit. A 12 volt ignition source can be found under the LHS of the steering column pink wire with white trace.(Check this with test light.) Carry out wiring as per the wiring diagram. Run the twin core under the dash, behind the glove box and under the scuff plate then exit out through the floor under the LH front seat (Drill an 8mm hole and use grommet supplied), run to rear of the vehicle for later connection to the fuel pump and sender unit.
2. Remove transfer case bash plate. Cut exhaust pipe 150mm from back face of OEM resonator. Loosen front clamp and unclip rubbers from pipe and remove exhaust section. Bolt 3 bolt flange to new exhaust section. Lift in place, check for alignment and tack weld to OEM tail pipe. Remove bolts and fully weld. After welding refit together with gasket and heat shield. Secure front of pipe with new C 12 clamp and original rubber mount. Use hi temperature sealer on all exhaust joints.
3. Remove the LHR wheel arch cover and the LHR tail light assembly, remove the OEM filler, fast fill and 8mm vent lines (Note you will need to cut the filler neck to get it out). Make sure you disconnect from the original tank before cutting. The neck and pipes will not be reused. Carefully remove the couplings from the tank ends of both the fast fill vent and the 8mm vent lines. Also the fast fill vent end Cap that is riveted or cable tied to filler neck. Screw the P6 5/8 x 3/8 and the P6 5/16 x 1/8 elbows into the filler neck. Fit the 1500mm length of 16mm hose and the 1400mm length of 8mm hose to the new filler neck, fit the fast fill vent end cap to the 1050mm length of 16mm hose and attach to the bracket on the new filler neck or cable tie, depending which type you have. Refit the new neck to the vehicle and fix to body with M6 x 16mm bolt washers and nyloc nut. Fit 420mm length of 32mm hose to the fill neck. Screw the P3 5/16 x 1/8 straight fitting into the intermediate pipe and fit pipe in position connecting back to the original tank with the original hose. There are two sizes of intermediate pipes. If you have the large tube 32mm diameter you will need to cut 40mm off the small end of the first intermediate hose and replace the OEM tank hose with it. Wait to tighten clamps until auxiliary tank is in position.

4. Remove the emission canister from the vehicle and unbolt the unit from the OEM bracket. Fit the canister to the new bracket and secure with M8 nyloc and washer. The new bracket with canister locates under the R/H stud from the park brake cable support and four TEK screws along the rear. The 1050mm length of 16mm hose that comes from the fast fill vent end cap now connects to the FRONT fitting on the canister in its new location. The REAR fitting uses one of the original couplings and the 600mm length of 16mm hose and loops forward on to the 16mm coupling that comes from the top of the original tank.

5. Screw the fittings into the tank P6 5/8 x 3/8 elbow points towards the filler neck and P3 5/16 x 1/4 straight goes into the fuel pick up. Before jacking tank into position fit from top M10 x 65 bolt with 4mm thick, 40mm diameter heavy washer in left hand front outside slot. Also drill 10.5 diameter hole in centre of left hand side rear outer slot. Jack tank into position, secure inside front mount with M10 x 60 bolt. Once tank is in position mark and drill in board rear mount, secure with M10 x 75 bolt nut and washers. Secure left hand rear mount with remaining M10 x 75 bolt with washers and nyloc nut. Screw the fuel transfer pump to the mounting bracket and mount above the rear of the auxiliary tank and complete the wiring of the pump. Connect remaining hoses and sender unit wires (including the earth). Cover auxiliary tank pump line with 16mm condu flex. Check all clearances and neatly cable tie all hoses and wiring. Refit wheel arch cover and tail light.



FITTING KIT CONTENTS JWJK2PA36

Brass	Electrical
<ul style="list-style-type: none"> ○ 1 x P3 5/16 X 1/8 Straight ○ 1 x P3 5/16 X 1/4 Straight ○ 1 x P6 5/16 x 1/8 Elbow ○ 2 x P6 5/8 x 3/8 Elbow 	<ul style="list-style-type: none"> ○ 1 x LRA-PG210 Switch Gauge ○ 1 x 3mm Two Core @ 3m ○ 1 x 5 AMP Fuse ○ 1 x Fuse Holder ○ 2 x Fuse Holder Terminals ○ 1 x 4mm Single Core Blue @ 300mm ○ 1 x Red Insulated Terminal ○ 3 x 5mm Red Eye Terminals ○ 1 x 3/16 Wiring Grommet ○ 3 x Heat Shrink Tube
Bolts / Nuts	Misc Parts
<ul style="list-style-type: none"> ○ 1 x M8 Nyloc Nut ○ 1 x M8 x 25 Washer ○ 1 x M10 x 60mm Bolt ○ 2 x M10 x 75mm Bolt ○ 1 x M10 x 65mm Bolt ○ 2 x M6 Flat Washers ○ 3 x M10 x 30mm Flat Washers ○ 4 x M10 x 25mm Flat Washers ○ 4 x M10 Nyloc Nuts ○ 5 x M5 x 8 Pan Head Screws ○ 1 x M6 x 16mm Bolt ○ 1 x M6 Nyloc Nut ○ 5 x Tek Screws ○ 2 x 30mm Tek Screws ○ 2 x Tek Screws 25mm long 	<ul style="list-style-type: none"> ○ 1 x SC91 Fuel Cap ○ 1 x FNJWJKPA Filler Neck ○ 1 x FPJWJKDA Intermediate Fill Pipe ○ 2 x 25mm IDP Clip ○ 1 x 16mm IDP Clip ○ 1 x Canister Bracket 3.6 type ○ 2 x 16mm Conduflex @ 320mm ○ 1 x 4mm 40 diameter washer
Hose Clamps	Cable Ties
<ul style="list-style-type: none"> ○ 7 x 1/4 Hose Clamp ○ 6 x 5/8 Hose Clamp ○ 4 x 1" 1/4 Hose Clamp ○ 1 x EFI Hose Clamp 	<ul style="list-style-type: none"> ○ 10 x 7" Cable Ties ○ 5 x 11" Cable Ties

Hose	Filters
<ul style="list-style-type: none"> ○ 1 x 8mm Hose @ 1100mm ○ 1 x 8mm Hose @ 1400mm ○ 1 x 32mm Hose @ 100mm ○ 1 x 32mm Hose @ 420mm ○ 1 x 16mm NTP Hose @ 600mm ○ 1 x 16mm NTP Hose @ 1050mm ○ 1 x 16mm NTP Hose @ 1500mm 	<ul style="list-style-type: none"> ○ 1 x Z14K Filter ○ 1 x Fuel Pump ○ 1 x Fuel Pump Mounting Bracket
Sender	8 Pages Instructions Consisting Of:
<ul style="list-style-type: none"> ○ 1 x 0-90 OHM Sender Unit c/w 400mm Earth 	<ul style="list-style-type: none"> ○ 2 x Pages Fitting Instructions ○ 2 x Page Fitting Kit Contents ○ 1 x Page Exhaust Mod Kit Content ○ 1 x WDSGPG210 ○ 1 x Page Exhaust Modification Pictures ○ 1 x Page Crop of 4 Pictures

Kit Packed By _____

Checked By _____



FITTING KIT CONTENTS

Bolts / Nuts:	Misc Parts:
<ul style="list-style-type: none">○ 3 x M10 x 30 Bolts○ 3 x M10 Spring washers○ 3 x M10 x 20 Washers○ 1 x C12 Exhaust clamp	<ul style="list-style-type: none">○ Exhaust heat shield – JK 2 Door Pentastar Type○ 1 x Resonator and pipe section○ 1 x 3 Bolt flange – 63 diameter hole○ 1 x 3 Bolt flange gasket

Kit Packed By _____

Checked By _____

JWJK2PA36 FITTING INSTRUCTION PHOTOS

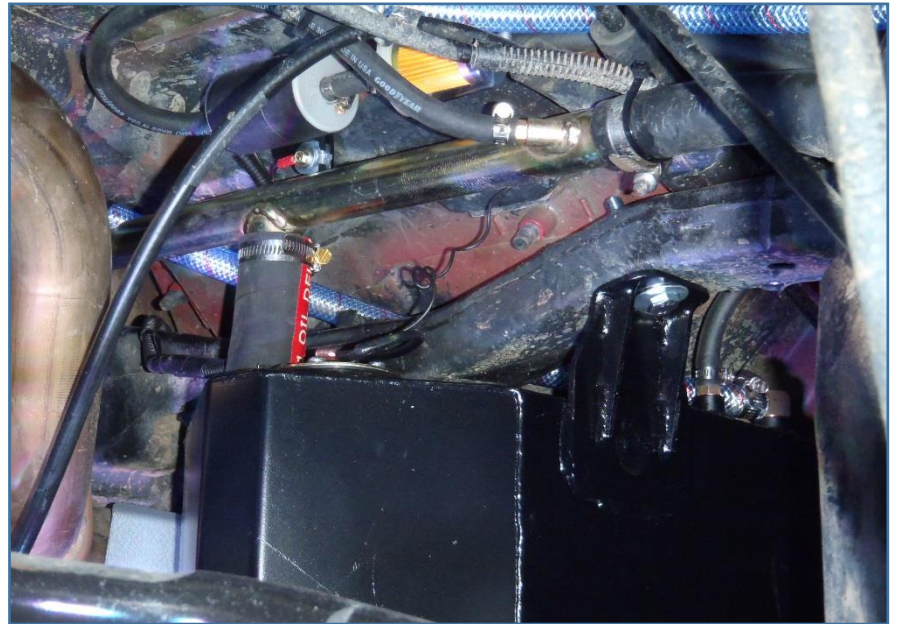
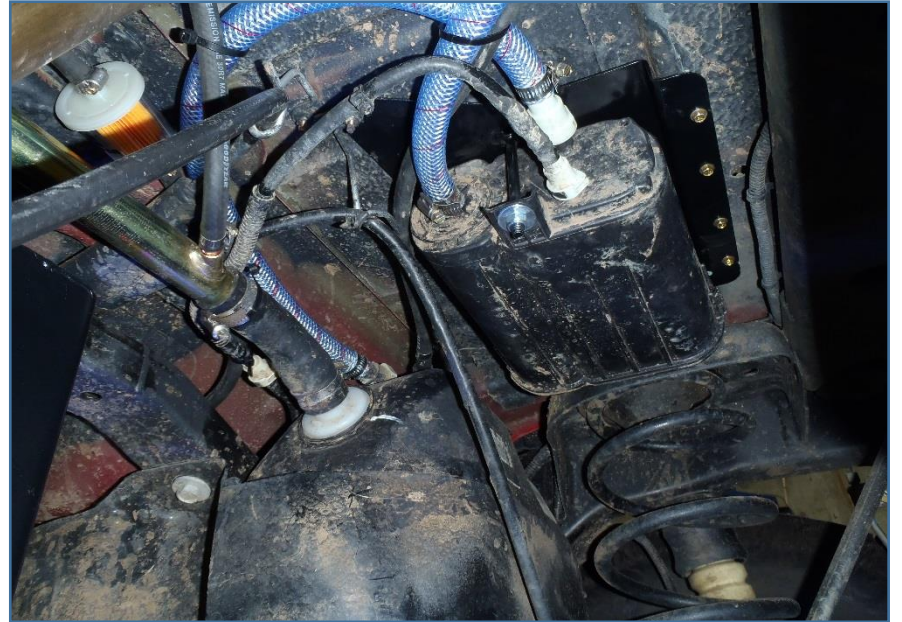

JWJK2PA36 EXHAUST MODIFICATION PHOTO



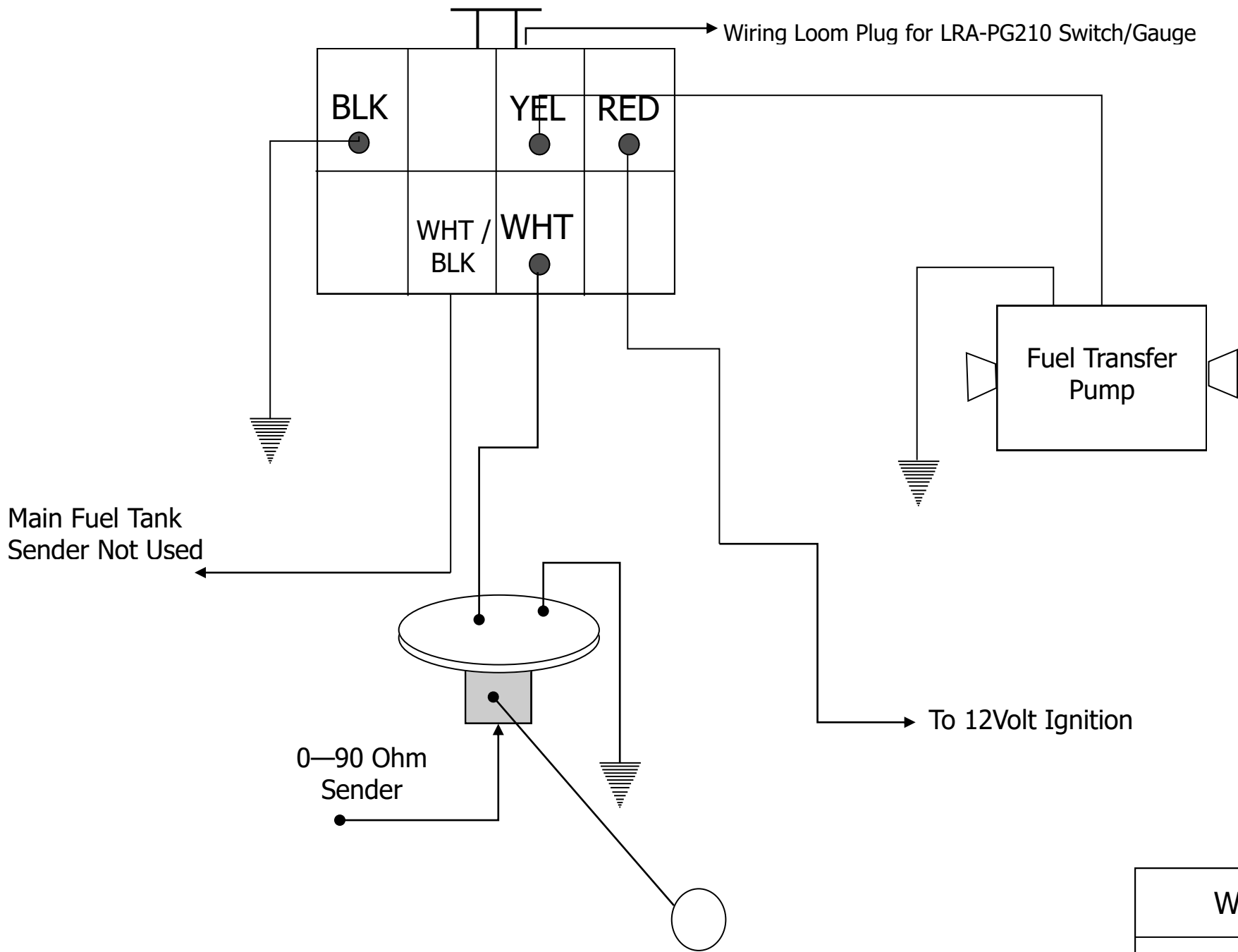

WDSGPG210