



**Installation Instructions for: JWJLPA
Jeep Wrangler JL 4 Door Petrol
64L Auxiliary Tank**

Revised 10/19

This auxiliary tank fits under the center of the vehicle on the LH side of the drive shaft. Filling is via a t-piece in the fill line. Both tanks will fill at the same time. Fuel is transferred via an electric pump that will pump fuel from the auxiliary tank into the OEM tank. A combination switch/gauge unit will be located in a suitable position on the dash. When the switch is in operation an **ORANGE** light will be on, indicating that the transfer pump is in operation. A series of lights will also indicate the fuel level. All **GREEN** lights showing FULL, one **RED** light showing EMPTY. When the pump is in operation and the tank is empty, the red light will flash. The pump will then run for 2 minutes and automatically shut off.

(DO NOT OPERATE TRANSFER PUMP WITH NO FUEL IN THE AUXILIARY TANK OR PUMP FAILURE WILL OCCUR).

1. Select a suitable location for the switch/gauge unit. We suggest on the RH side of the steering column in the small panel just below the headlight switch for right hand drive vehicles. This needs to be accurately fitted as there is minimal clearance for any variation (**Refer Pic 1**). Part of the under section may need to be removed. A 12V ignition source can be found in the wiring loom on the LH side of the steering column. Pink wire yellow trace (check with test light). Carry out wiring as per diagram. Run 2 core wire to RH side of kick panel and under front and rear scuff plates exit wire through the grommet in the RHR dog leg. Run to rear of the vehicle for later connection of fuel pump and sender unit.
2. Remove stud from underside of the center chassis cross-member (**Refer Pic 2**). Disconnect the exhaust at the joint near the transfer case. Partially lower pipe to be able to fit new front secondary mount. Also swing original tank support out of the way. The new bracket fits around the chassis and is secured with 4 x M8 x 20 bolts. It has a slot in the base of the bracket for the original tank support. Refit this once the tank is installed. Reconnect the exhaust and fit the muffler and pipe heat shields. Also fit the heat shield to the rear of the tank.

3. Disconnect the filler hose from main tank and filler pipe. Unbolt fuel separator from the fill pipe. You can either remove fill pipe from vehicle or cut pipe in location. Measure 40mm from fuel separator bracket and cut the filler (**Refer Pic 3**). Cut unwanted part of the bracket so rubber joining hose can slip over the fill pipe. If cutting in situation after cutting, bend bracket up and recut as close as possible to the remaining fuel separator tab. Fit new tee filler section to fill pipe using 75mm of 38 diameter hose and clamps. Use fuel separator for location of new tee filler. Make sure T is pointing down. Also fit P3 5/16 x 1/8 straight fitting and 430mm of 8mm fuel hose at this time. Reconnect tee filler to main tank. Tighten all clamps.
4. Disconnect canister tube from pump assembly and unclip at chassis rail near front of the RH wheel. Remove tube from the vehicle. Remove fittings from tube. Be careful not to damage the barbs on the fittings. Fit straight quick connect fitting to 500mm of 1/2" hose (**Refer Pic 4**). Refit to the vehicle in the same location but now run over OEM tank fill hose. Open up securing clamp at chassis to fit larger hose. Fit T piece to other end. Fit elbow quick connect fitting to 300mm 1/2" hose. Connect to pump assembly and connect other end to T piece. Fit 95mm of 35 diameter hose to new T filler.
5. Fit 400mm of 1/2 hose to FLVV and install brass into tank (**Refer Pic 5**). Jack tank into position and feed 35 diameter hose onto filler neck. Secure rear and inboard mount with 3 x M12 x 1.5 bolts. Secure front of the tank to new secondary bracket with M10 x 30 bolts, washers and Nyloc nuts. Connect FLVV 1/2 hose to canister tee.
6. Fit fuel pump to mounting bracket and mount to RH stud on crossmember above diff. Screw M/F 1/8 elbow to pick up side of pump and fit filter to this. Connect fuel pick up hose to filter. Connect previously fitted 5/16 hose from filler tee to outlet side of the pump.
7. Complete electrical wiring by connecting white wire to sender, yellow to the pump and connect earth wires.
8. Check all clearances and neatly cable tie all hoses and wiring. Refit tubular crossmember tank support.



FITTING KIT CONTENTS – JWJLPA

Updated 9/23 - TL

Updated 9/23 - TL	
Brass: <ul style="list-style-type: none"> ○ 1 x 25C 1/8 M & F Elbow (For Pump) ○ 1 x P3 5/16 x 1/8 Straight ○ 1 x P6 5/16 x 1/4 Elbow ○ 1 x 12mm Plastic Tee 	Electrical: <ul style="list-style-type: none"> ○ 1 x LRA-PG210 Switch/Gauge ○ 1 x 3mm Two Core @ 5000mm ○ 1 x 4mm Single Core Blue Wire @ 300mm ○ 1 x 5 AMP Fuse ○ 1 x Fuse Holder ○ 2 x Fuse Holder Terminals ○ 2 x Red Insulated Terminal ○ 1 x Red Male Terminal ○ 1 x 5mm Red Eye Terminal ○ 1 x 8mm Blue Eye Terminal ○ 4 x 3mm Shrink Tube
Bolts / Nuts: <ul style="list-style-type: none"> ○ 4 x M8 x 20 Bolts ○ 2 x M10 x 30 Bolts ○ 3 x M12 x 30 1.5 Fine Thread Bolts ○ 15 x M8 x 20 Washers ○ 4 x M10 x 25 Washers ○ 3 x M12 Spring Washers ○ 8 x M8 Nyloc Nuts ○ 2 x M10 Nyloc Nuts ○ 2 x M12 x 30 H/D Washers ○ 1 x M12 Washer 25Ø ○ 2 x 25mm Tek Screws 	Misc Parts: <ul style="list-style-type: none"> ○ 1 x 38Ø Tee Filler ○ 1 x Muffler Shield ○ 1 x Pipe Heat Shield with Nuts & Clamps ○ 1 x Front Secondary Bracket (2 Pieces) ○ 1 x Tank Heat Shield ○ 2 x C12 Exhaust Clamps ○ 1 x FLV 60-12 Valve ○ 1 x BS337 O-Ring ○ 6 x M5 x 10 Cap Screws ○ 6 x M5 Spring Washers ○ 1 x ICV
Hose Clamps: <ul style="list-style-type: none"> ○ 6 x 1/2 Hose Clamps ○ 2 x 1 1/4 Hose Clamps ○ 2 x 1 1/2 Hose Clamps ○ 4 x EFI Hose Clamps ○ 1 x 16mm P Clip 	Hose: <ul style="list-style-type: none"> ○ 2 x 8mm Hose @ 430mm ○ 1 x 12mm Hose @ 300mm ○ 1 x 12mm Hose @ 370mm ○ 1 x 12mm Hose @ 500mm ○ 1 x 35mm Hose @ 95mm ○ 1 x 38mm Hose @ 75mm

Pumps & Filters:	Cable Ties:
<ul style="list-style-type: none"> ○ 1 x Fuel Pump & Filter ○ 1 x Fuel Pump Mounting Plate 	<ul style="list-style-type: none"> ○ 3 x 11" Cable Ties
Sender:	8 Pages of Fitting Instructions Consisting of:
<ul style="list-style-type: none"> ○ 1 x 0-90 OHMS Sender C/W 150mm Earth, Installed Using: <ul style="list-style-type: none"> - 5 x M5 x 10 Pan Heads - 5 x M5 Spring Washers 	<ul style="list-style-type: none"> ○ 2 x Pages Fitting Instructions ○ 2 x Pages Fitting Kit Contents ○ 3 x Pages Reference Pictures ○ 1 x Pages Wiring Diagram

Kit Packed By _____

Checked By _____

Picture 1



Picture 2



Picture 3

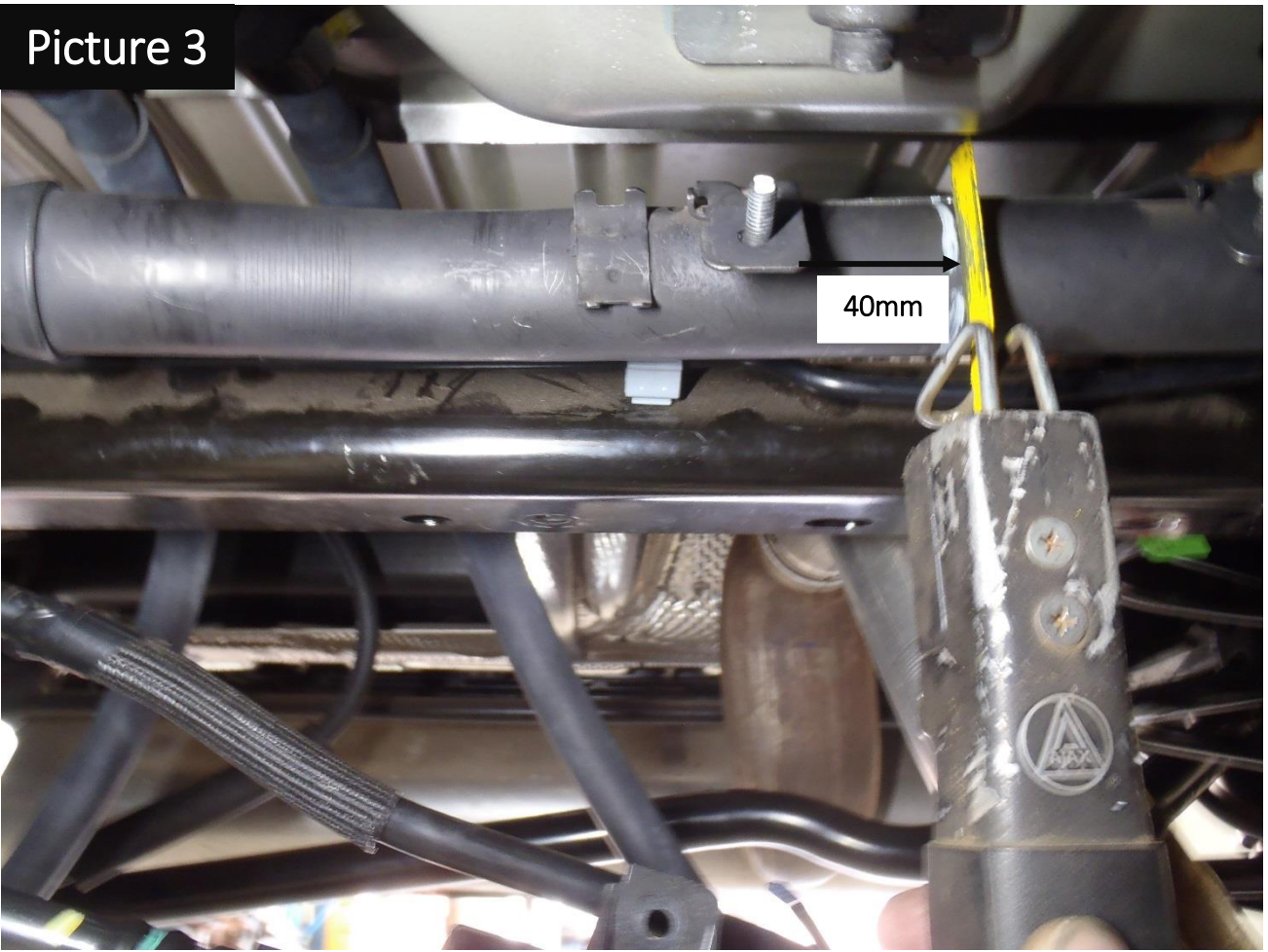

Picture 4



Picture 5

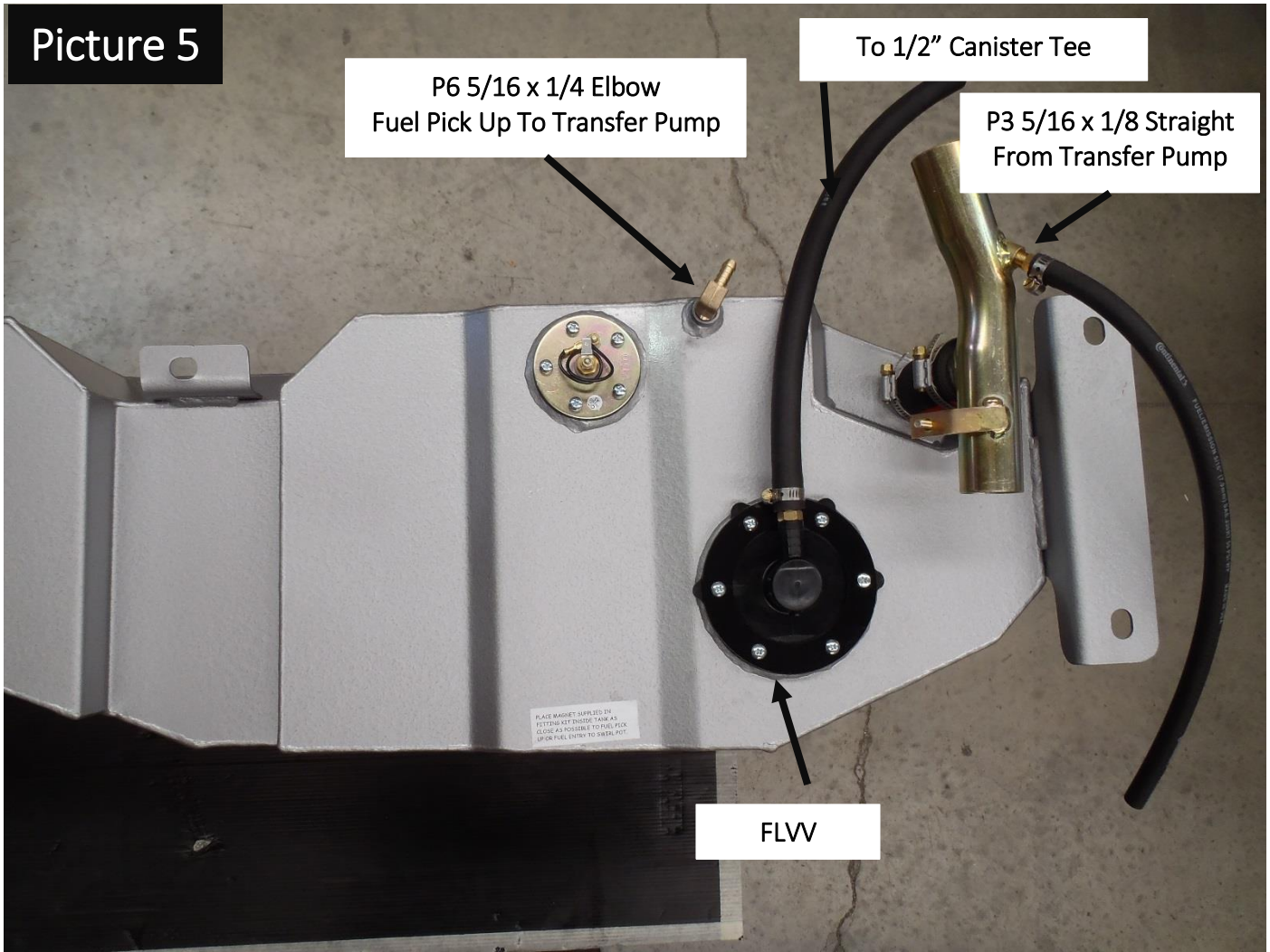

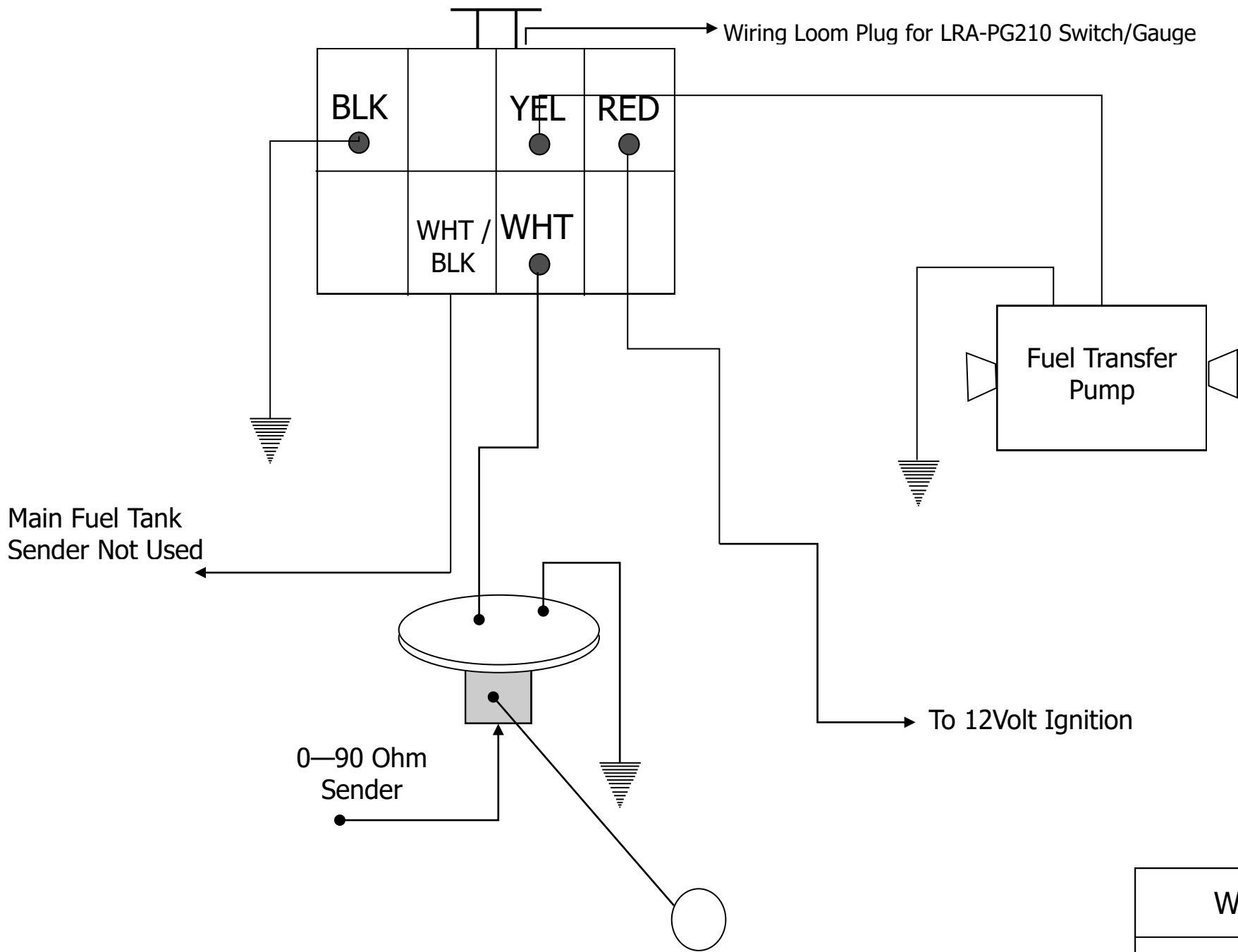

WDSGPG210