



Installation Instructions for LD3A
Landrover Discovery III
110L Auxiliary Tank

This Auxiliary tank fits under the rear of the vehicle and takes the place of the spare wheel. Fuel is transferred via an electric pump that will pump fuel from the auxiliary tank into the OEM tank. A combination switch/gauge will be located into a suitable position in the dash. When the switch is in operation an **ORANGE** light will be ON, indicating that the transfer pump is in operation. A series of lights will also indicate fuel level. All **GREEN** lights on showing FULL, one **RED** flashing light showing EMPTY.

(DO NOT OPERATE TRANSFER PUMP WITH NO FUEL IN AUXILIARY TANK OR PUMP FAILURE WILL OCCUR).

1. Select a suitable place in the dash to mount the switch/gauge unit. There are limited options for this, however, we suggest placing it in the soft part of the dash on the tacho side. Complete the wiring (**refer WDSGPG210 diagram**) and run the twin core sheathed cable to the rear of the vehicle.
2. Remove the spare wheel and unbolt the wheel winch. Remove the RH rear wheel, and the inner wheel arch cover. From the centre of the 45° bend on the standard filler neck, mark a point 110mm down the fill pipe and cut with a chain pipe cutter, (**Refer Diagram**). Disconnect fast fill and vent lines and remove standard filler neck.
3. Remove the inner bolts from the chassis rail that bolt the counter weight dampeners to the chassis. Directly above this bolt, drill the existing hole out to 9mm diameter. Install secondary brackets by starting counter weight bolt. Using M8 x 20mm bolts, Nyloc nuts and washers fix bracket to top hole. Tighten counter weight bolt.
4. Bolt the front secondary bracket in between the chassis and exhaust cover, then enlarge the existing holes in the cover to clear the bolt head on the secondary bracket. Re-drill 2 M8 holes in cover to fix cover back to secondary bracket. Using the fuel pump mounting bracket, M5 x 20mm counter sunk screws and nuts. Mount the fuel transfer pump to the bracket and bolt the pump to the hole which is up inside the top of the RH rear shock absorber mount. Use the M8 bolt that has the strap attached to accomplish this.

5. Install fittings in the tank (**Refer Diagram**) and fit 1400mm length of 6mm hose to the P6 1/4 x 1/8 elbow and the 750mm length of 16mm hose to the P6 5/8 x 1/4 elbow on the tank. Lift the tank into position, being careful not to trap any of the hoses in between the top of the tank and the chassis. Bolt in place with M10 fine thread Nyloc nuts, washers and M10 x 25mm fine thread bolts with straps attached.
6. Assemble fittings in twin filler (**Refer Diagram**). Slip the 90mm length of 35mm hose on the main tank branch of the twin filler and bolt filler in place. Connect the fill pipe from the twin filler to the auxiliary tank with 2 x 100mm lengths of 38mm hose. Connect the 16mm fast fill vent from the auxiliary tank to the 16mm elbow on the back of the twin filler and the original main tank fast fill vent to the 16mm elbow on the front side of the twin filler. The 1400mm length of 6mm hose previously connected to the auxiliary tank goes to the 6mm elbow on the top of the twin filler. Connect the 8mm fuel pick up to the in line filter then to inlet side of the transfer pump and the outlet side of pump to the remaining 8mm elbow in the twin filler.
7. Complete wiring of the transfer pump and sender unit. Neatly cable tie all hoses and wiring, check operation and refit inner wheel arch cover.



FITTING KIT CONTENTS LD3A

Brass: <ul style="list-style-type: none"> ○ 1 x P3 5/16 x 1/4 Straight ○ 1 x P6 5/16 x 1/4 Elbow ○ 3 x P6 5/8 x 1/4 Elbow ○ 2 x P6 1/4 x 1/8 Elbow 	Electrical: <ul style="list-style-type: none"> ○ 1 x 3mm Two Core @ 5500mm ○ 2 x Red Terminals ○ 1 x Red Eye Terminal 6mm ○ 1 x Blue Eye Terminal 8mm ○ 1 x Red Male Terminal ○ 2 x Shrink Tube @ 35mm ○ 1 x LRA-PG210 Switch/Gauge Unit
Bolts / Nuts: <ul style="list-style-type: none"> ○ 4 x M8 x 20 Bolts ○ 6 x M8 x 25 Flat Washers ○ 2 x M8 Spring Washers ○ 8 x M10 x 25 Flat Washers ○ 3 x M8 Nyloc Nuts ○ 6 x M10 Fine Thread Nyloc Nuts ○ 2 x M5 Washers ○ 1 x M8 x 20 Flat Washers ○ 2 x M5 x 20 Counter Sunk Screws ○ 2 x M5 Nuts 	Misc Parts: <ul style="list-style-type: none"> ○ 1 x M8 x 20 Bolt on 170 Strap ○ 2 x M10 x 25 Fine Thread Bolt on 150 Strap ○ 1 x Twin Filler #TFLD3A ○ 1 x #FPLD3A Fill Pipe ○ 3 x Secondary Brackets ○ 1 x Fuel Pump Mounting Plate ○ 1 x Non Locking Cap
Hose Clamps: <ul style="list-style-type: none"> ○ 8 x 1/4 Hose Clamps ○ 3 x 5/8 Hose Clamps ○ 6 x 1 1/4" Hose Clamps 	Cable Ties: <ul style="list-style-type: none"> ○ 10 x 7" Cable Ties ○ 2 x 11" Cable Ties
Sender: <ul style="list-style-type: none"> ○ 1 x 0-900HM with 800mm Earth Lead 	Pumps & Filters: <ul style="list-style-type: none"> ○ 1 x Z14K Filter ○ 1 x Fuel Pump

Hose:	8 Pages of Fitting Instructions Consisting of:
<ul style="list-style-type: none">○ 1 x 8mm Hose @ 1100mm○ 1 x 35mm Hose @ 90mm○ 2 x 38mm Hose @ 100mm○ 1 x 6mm NTP Hose @ 1400mm○ 1 x 16mm NTP Hose @ 750mm	<ul style="list-style-type: none">○ 2 x Pages Fitting Instructions○ 2 x Pages Fitting Kit Contents○ 1 x Page WDSGPG210 Diagram○ 1 x Page Filler Neck Mod Diagram○ 1 x Page Tank Brass Fittings Diagram○ 1 x Twin Filler Fittings Diagram

Kit Packed By _____

Checked By _____

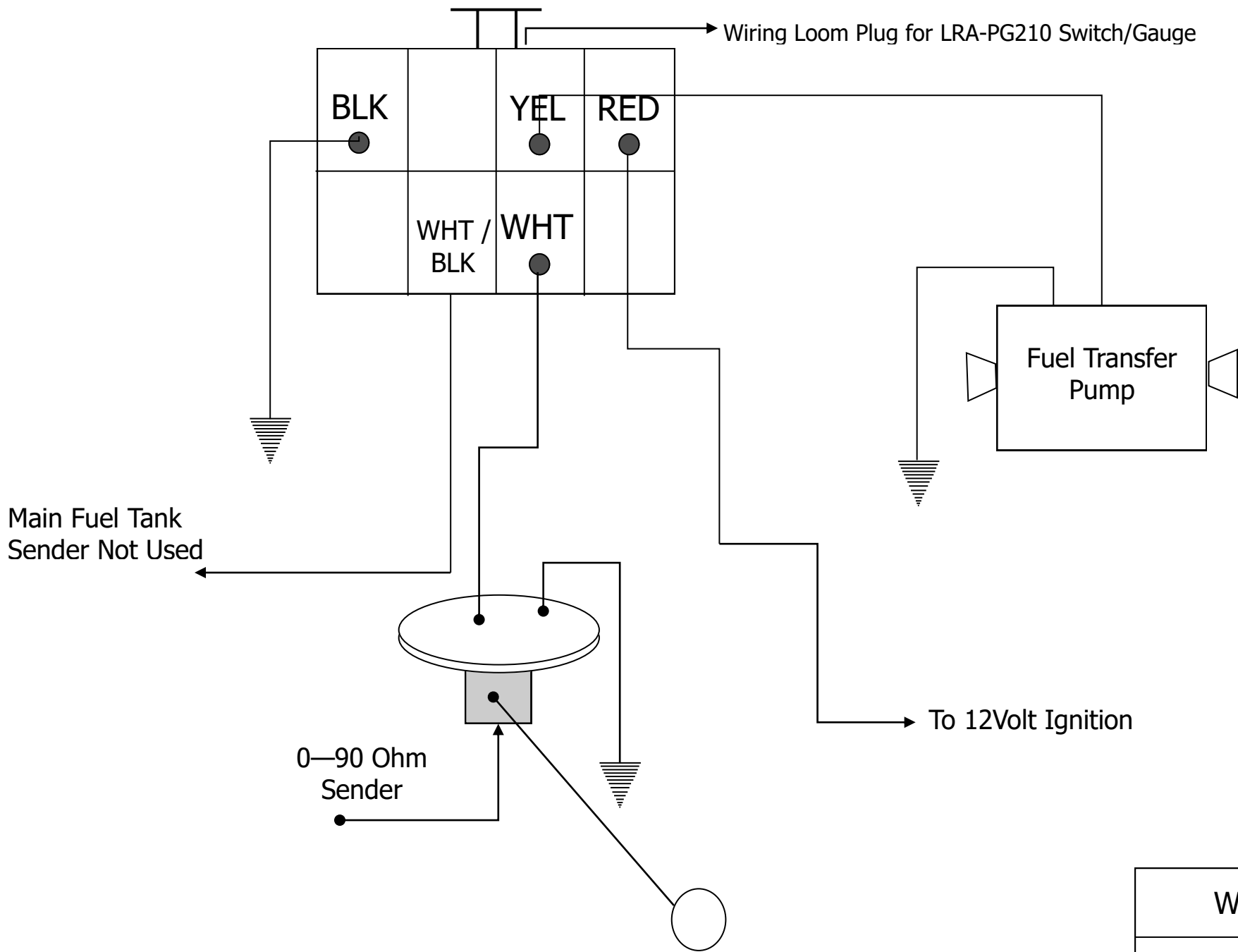

WDSGPG210

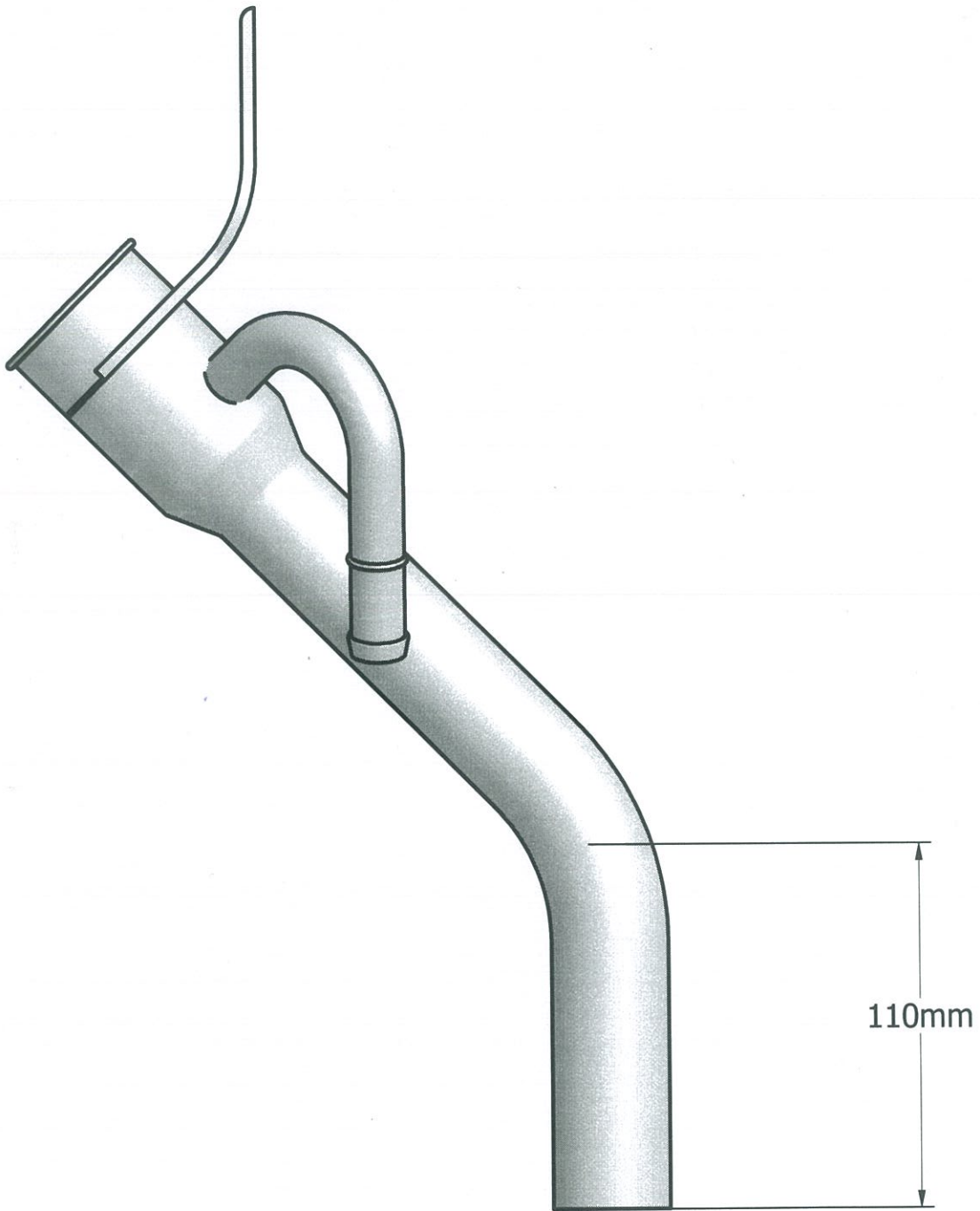

THIS DRAWING REMAINS THE PROPERTY OF
LONG RANGE AUTOMOTIVE AND IS NOT TO BE DUPLICATED
WITHOUT PERMISSION



LD3A

INSTALLATION

Land Rover Discovery series 3
110ltr rear aux.
Filler neck modifications.

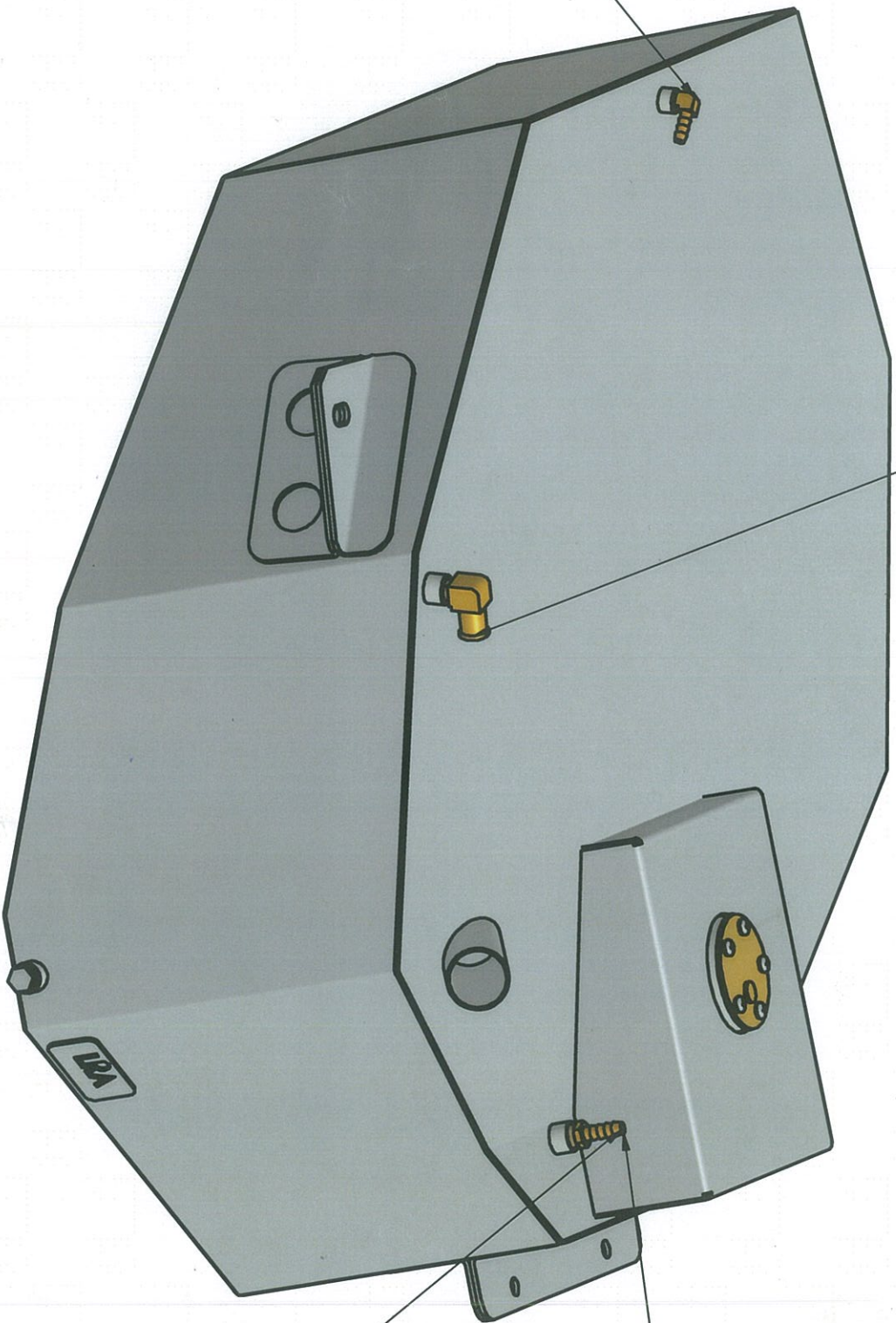

ITEM	QTY	DESCRIPTION
1	1	P6 1/4 x 1/8 elbow
2	1	P6 5/8 x 1/4 elbow
3	1	P3 5/16 x 1/4 straight

THIS DRAWING REMAINS THE PROPERTY OF
 LONG RANGE AUTOMOTIVE AND IS NOT TO BE DUPLICATED
 WITHOUT PERMISSION



LD3A

INSTALLATION

Land Rover Discovery series 3
 110ltr rear aux.
 Brass fittings installation.

FUEL PICKUP



P6 5/8x1/4 elbow

P6 5/8x1/4 elbow

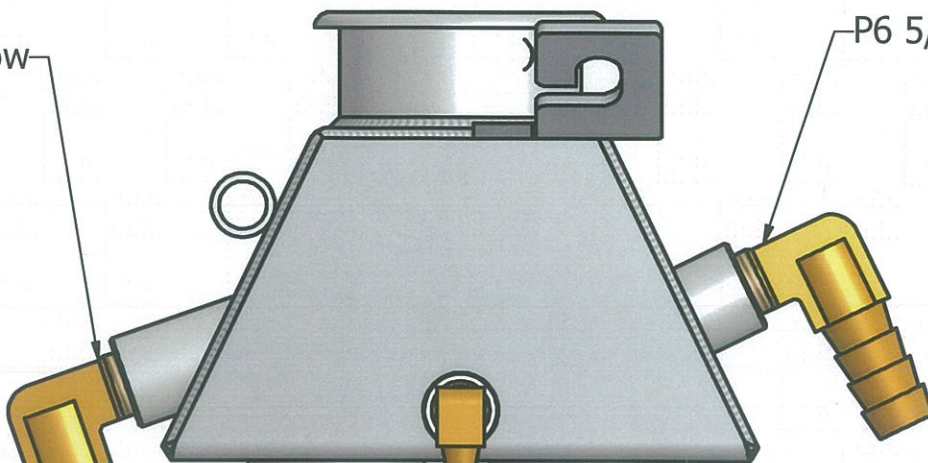

P6 1/4x1/8 elbow

P6 5/16x1/4 elbow



LD3A

INSTALLIATION

Land Rover Discovery Series 3
110Ltr Rear Aux.
Twin filler brass fittings installiation.

THIS DRAWING REMAINS THE PROPERTY OF
LONG RANGE AUTOMOTIVE AND IS NOT TO BE DUPLICATED
WITHOUT PERMISSION

