



## Installation Instructions for LDEF90 Landrover Defender 90 SWB Diesel 50L Auxiliary Tank

This auxiliary fuel tank fits up under the rear of the vehicle. Because this auxiliary tank is located at the rear of the vehicle, rework of exhaust system may be required. The auxiliary tank has its own filling point, this is flush mounted into the right hand rear quarter panel. Fuel is transferred via an electric pump that will pump fuel from the auxiliary tank into the OEM tank. A combination switch/gauge will be located into a suitable position in the dash. When the switch is in operation an **ORANGE** light will be on, indicating that the transfer pump is in operation. A series of lights will also indicate fuel level. All **GREEN** lights ON showing FULL, one **RED** light flashing showing empty.

**(DO NOT OPERATE TRANSFER PUMP WITH NO FUEL IN AUXILIARY TANK OR PUMP FAILURE WILL OCCUR).**

1. Install combination switch/gauge and associated wiring as per wiring diagram provided. In some cases the switch/gauge may be mounted into the dash, in other cases it may be more convenient to mount switch/gauge under the dash, using the mounting box supplied.
2. Remove (if applicable) any exhaust system that is behind rear axle assembly. Install brass fittings into new tank, the socket adjacent to the fill neck is the fast fill socket. Install P3 1/2 x 1/4 straight fitting to this socket. Screw remaining 1/4" loose barb into the remaining socket. Test the OHM's reading of the gauge sender with the sender installed in the tank. **EMPTY** should read 0.5 - 2 OHMS, **FULL** should read 88 - 92 OHMS, if readings are outside this window correct before proceeding.
3. Lift tank up into position and secure using secondary brackets, nuts and bolts provided. Mount filler bucket into RHR quarter panel. The diagram supplied is the suggested location. BECAUSE OF VARIATIONS IN VEHICLE MANUFACTURE IT IS RECOMMENDED THAT THE DIAGRAM SUPPLIED BE USED AS A GUIDE ONLY. Install new filler neck and fast fill hose.

4. Mount transfer pump in a suitable location, the 12 x 8 x 6 "T" piece supplied is to be installed into the main tank fast fill hose. Connect fuel transfer hose to 8mm barb on "T" piece and the auxiliary tank vent hose to the 6mm barb. Connect any remaining hoses or wires and neatly cable tie all hoses and wires away from any moving parts. Fill tank with fuel and check for leaks.
  
5. Carry out rework of exhaust system and advise vehicle owner of correct operation.



## FITTING KIT CONTENTS LDEF90

<b>Brass:</b> <ul style="list-style-type: none"> <li>○ 1 x P3 5/16 x 1/4 Straight</li> <li>○ 1 x P3 1/2 x 1/4 Straight</li> </ul>	<b>Electrical:</b> <ul style="list-style-type: none"> <li>○ LRA-PG210 Combination Switch/Gauge</li> <li>○ 1 x 3mm Two Core Wire @ 4500mm</li> <li>○ 1 x Red Terminal</li> <li>○ 2 x 6mm Blue Eye Terminals</li> <li>○ 1 x 8mm Blue Eye Terminal</li> </ul>
<b>Bolts / Nuts:</b> <ul style="list-style-type: none"> <li>○ 8 x M8 x 25 Bolts</li> <li>○ 2 x M10 x 30 Bolts</li> <li>○ 16 x M8 Flat Washers</li> <li>○ 4 x M10 Flat Washers</li> <li>○ 8 x M8 Nyloc Nuts</li> <li>○ 2 x M10 Nyloc Nuts</li> <li>○ 3 x M5 Washers</li> <li>○ 3 x M5 Nuts</li> <li>○ 3 x M5 x 16 Countersunk Screws</li> <li>○ 5 x M5 x 10 Pan Head Screws</li> </ul>	<b>Misc Parts:</b> <ul style="list-style-type: none"> <li>○ 2 x Secondary Brackets</li> <li>○ 1 x 12 x 8 x 6 Double "T" Piece</li> <li>○ 1 x Filler Bucket with Grommet</li> <li>○ 1 x Filler Neck #FNLD90</li> <li>○ 1 x Locking Filler Cap</li> <li>○ 4 x 3mm Heat Shrink @ 25mm</li> </ul>
<b>Hose Clamps:</b> <ul style="list-style-type: none"> <li>○ 8 x 1/4" Hose Clamps</li> <li>○ 4 x 1/2" Hose Clamps</li> <li>○ 2 x 1 1/2" Hose Clamps</li> </ul>	<b>Cable Ties:</b> <ul style="list-style-type: none"> <li>○ 8 x 7" Cable Ties</li> <li>○ 4 x 11" Cable Ties</li> </ul>
<b>Sender:</b> <ul style="list-style-type: none"> <li>○ 1 x 220-004 VDO Sender set up in tank with 600mm Long Earth Lead</li> </ul>	<b>Pumps &amp; Filters:</b> <ul style="list-style-type: none"> <li>○ 1 x Z14 Filter</li> <li>○ 1 x Fuel Pump</li> </ul>
<b>Hose:</b> <ul style="list-style-type: none"> <li>○ 1 x 6mm Hose @ 1100mm</li> <li>○ 1 x 8mm Hose @ 950mm</li> <li>○ 1 x 44mm Hose @ 120mm</li> <li>○ 1 x 12mm NTP Hose @ 600mm</li> </ul>	<b>Pages of Fitting Instructions Consisting of:</b> <ul style="list-style-type: none"> <li>○ 2 x Pages Fitting Instructions</li> <li>○ 1 x Page Fitting Kit Contents</li> <li>○ 1 x Page WDSGPG210 Wiring Diagram</li> <li>○ 1 x Page INLDEF9001 Filler Location</li> <li>○ 1 x Page INLDEF9002 Hose &amp; Fittings</li> </ul>

Kit Packed By \_\_\_\_\_

Checked By \_\_\_\_\_

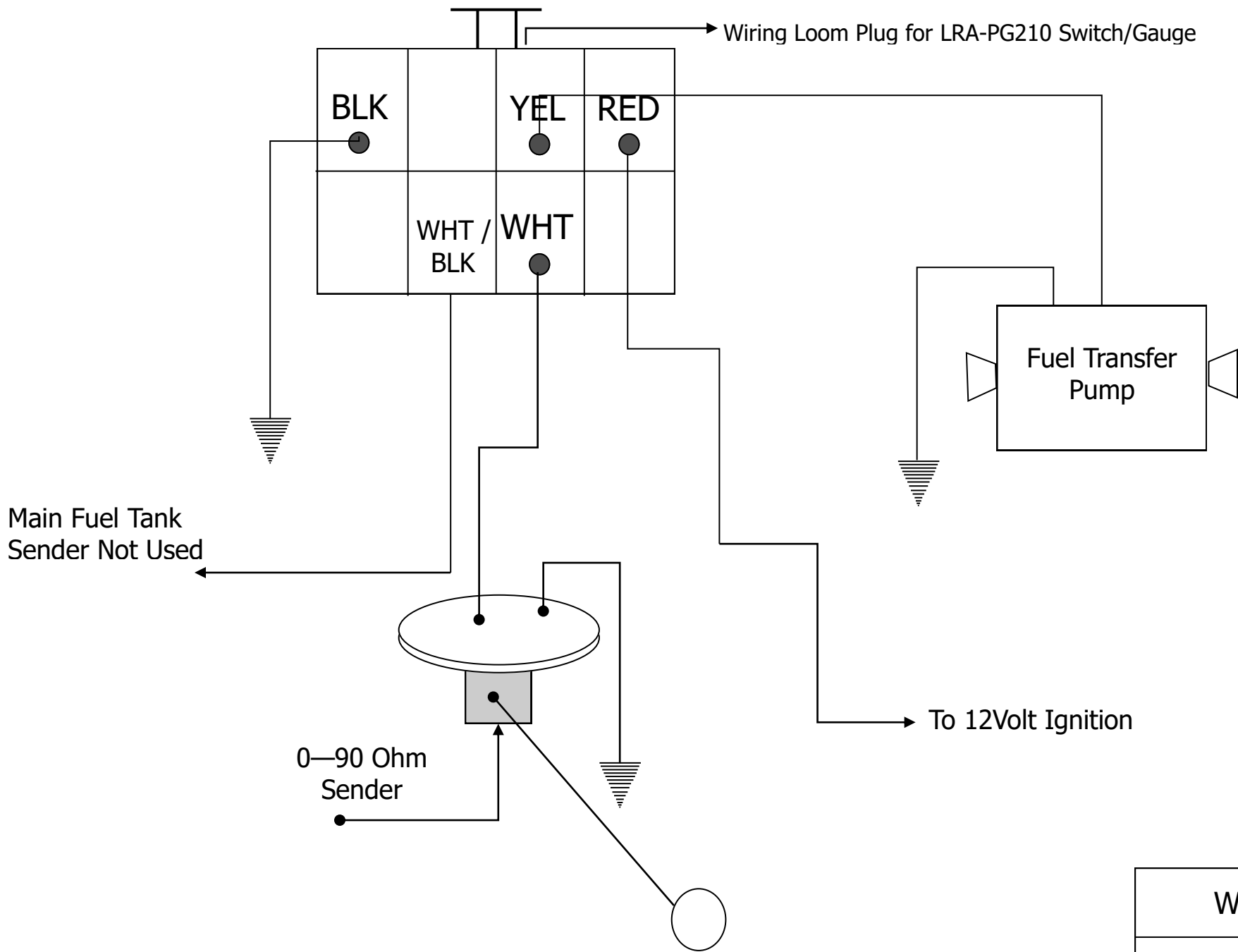

WDSGPG210

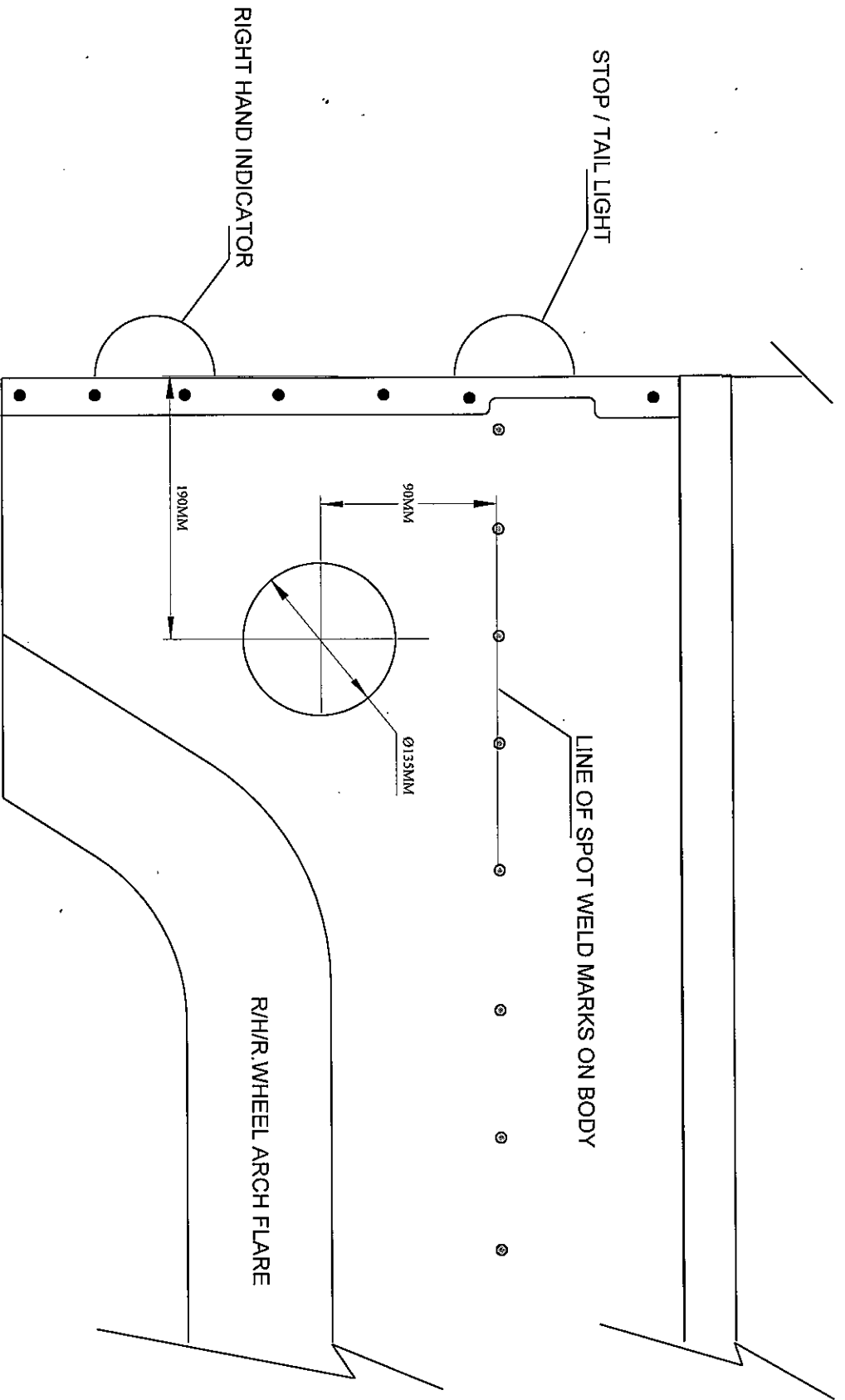

INLDEF9001
LANDROVER DEFENDER
Lt AUX TANK

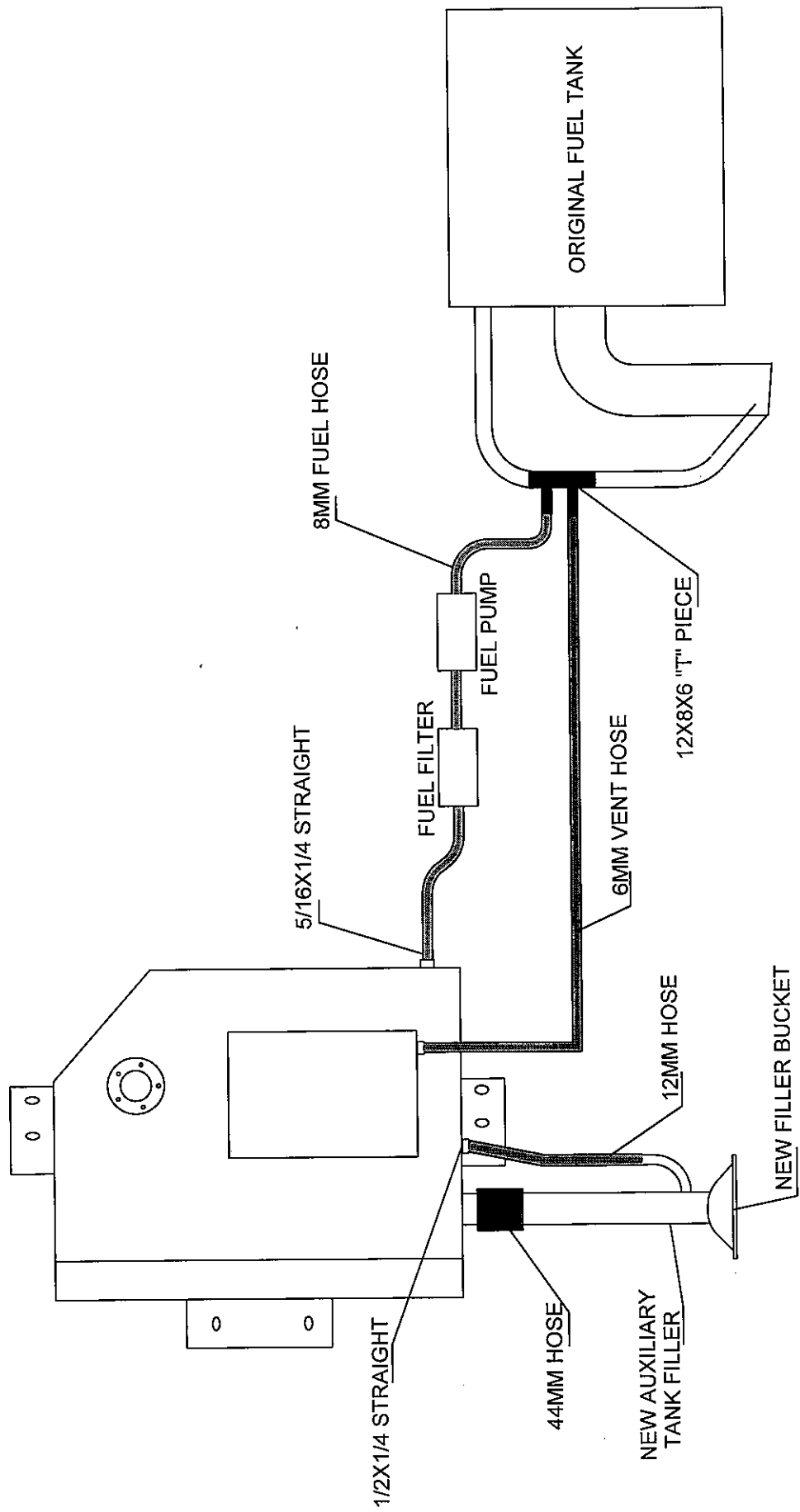

INLDEF9002
LANDROVER DEFENDER
Lt AUX TANK