



FITTING KIT CONTENTS TLCP120AX

<p>Brass:</p> <ul style="list-style-type: none"> ○ 1 x P6 5/16 x 1/4 Elbow ○ 1 x P6 1/2 x 1/4 Elbow ○ 1 X P3 5/16 x 1/8 Straight ○ 1 x P3 x 1/2 x 1/4 Straight ○ 1 x P14 1/4 Tee 	<p>Electrical:</p> <ul style="list-style-type: none"> ○ 1 x LRA-PG210 Switch/Gauge ○ 1 x 3mm Two Core x 5m ○ 1 x 4mm Single Core Blue Wire @300mm ○ 1 x 5AMP fuse ○ 1 x Fuse Holder ○ 2 x Fuse Holder Terminals ○ 2 x Red Earth Eye ○ 1 x Red Insulated Terminal ○ 3 x Heat Shrink @ 30mm
<p>Bolts / Nuts:</p> <ul style="list-style-type: none"> ○ 4 x M8 x 25mm Bolt ○ 2 x M10 x 90mm Bolt ○ 4 x M12 x 30mm Bolt Fine 1.25 pitch ○ 4 x M8 x 25mm Flat Washer ○ 4 x M8 Spring ○ 4 x M10 x 25mm Flat Washer ○ 2 x M10 Spring ○ 2 x M10 Nyloc Nut ○ 2 x M10 Nut ○ 4 x M12 Spring Washers ○ 4 x M12 x 30 mm Washer 	<p>Misc Parts:</p> <ul style="list-style-type: none"> ○ 1 x 35mm x 35mm x 32mm Tee Piece Filler ○ 1 x Roll Over Valve ○ 1 x LRA-FTG-2
<p>Hose Clamps:</p> <ul style="list-style-type: none"> ○ 10 x 1/4 Hose Clamp ○ 4 x 1/2 Hose Clamp ○ 6 x 1 1/4 Hose Clamp 	<p>Hose:</p> <ul style="list-style-type: none"> ○ 1 x 6mm Fuel Hose @ 1000mm long ○ 1 x 8mm Fuel Hose @ 800mm long ○ 2 x 12mm Fuel Hose @ 300mm long ○ 2 x 35mm Fuel Hose @ 140mm long ○ 1 x 32mm Fuel Hose @ 80mm long
<p>Pumps & Filters:</p> <ul style="list-style-type: none"> ○ 1 x Fuel Pump & Filter ○ 1 x Fuel Pump Mounting Plate 	<p>Cable Ties:</p> <ul style="list-style-type: none"> ○ 8 x 7" Cable Tie

Sender:	4 Pages of Fitting Instructions Consisting of:
<ul style="list-style-type: none">○ 1 x 0-90OHM Sender C/W 300mm Earth, Installed Using:<ul style="list-style-type: none">- 5 x M5 x 10mm Pan Heads- 5 x M5 Spring Washers	<ul style="list-style-type: none">○ 2 x Page Fitting Kit Contents○ 1 x Page Picture Hose and fitting Layout○ 1 x Page Wiring Diagram WDSGPG210

Kit Packed By _____

Checked By _____

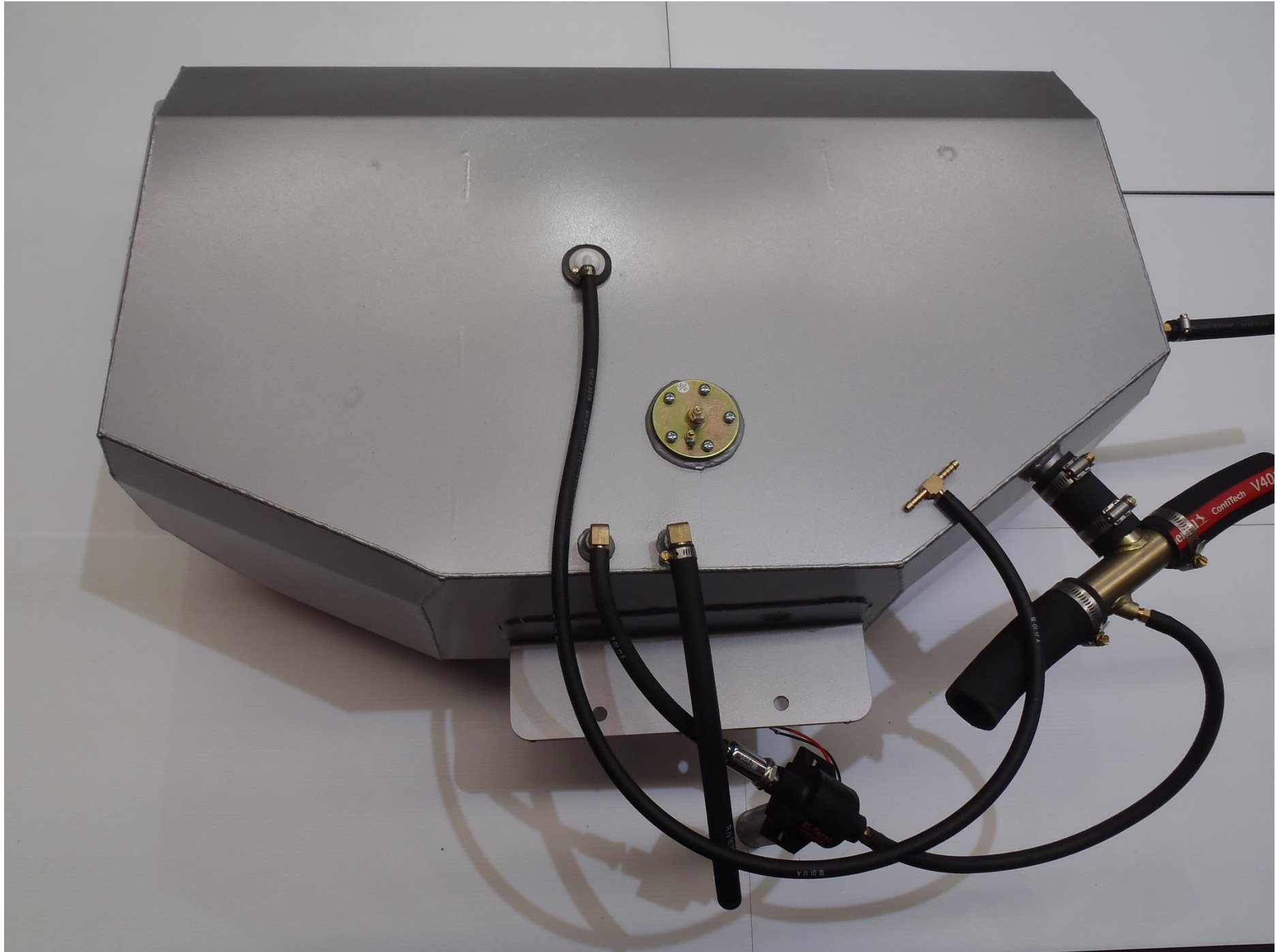

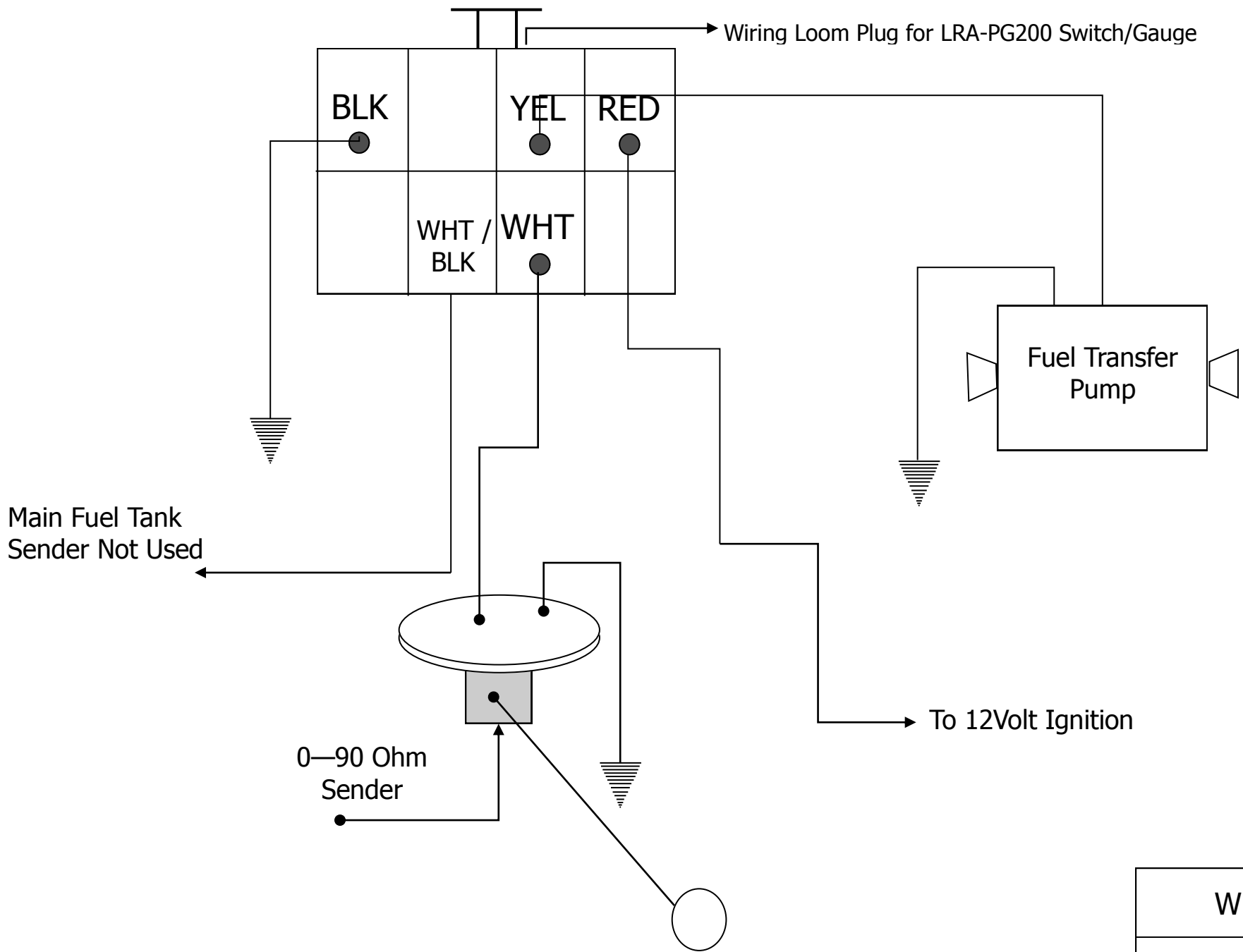

WDSGPG210