



**Installation Instructions for FMSA  
Ford Maverick DA Diesel SWB  
50L Auxiliary Tank**

This Auxiliary tank fits forward of the rear axle on the RHS of the drive shaft. Fuel is transferred via an electric pump that will pump fuel from the auxiliary tank into the OEM tank. A combination switch/gauge will be located into a suitable position in the dash. When the switch is in operation an **ORANGE** light will be on, indicating that the transfer pump is in operation. A series of lights will also indicate fuel level. All **GREEN** lights ON showing FULL, one **RED** light flashing showing empty.

**(DO NOT OPERATE TRANSFER PUMP WITH NO FUEL IN AUXILIARY TANK OR PUMP FAILURE WILL OCCUR).**

1. Carry out installation of wiring, switch/gauge and pump as per wiring diagram. Also mount fuel pump in a suitable location.
2. Remove the OEM filler bucket and its mounting grommet. Bend the mounting tab for the OEM filler up into the wheel arch. (This will not be used again). Install all brass fittings into new twin filler at the points shown in diagram. Twin filler can now be installed. The notch in the mounting face of the twin filler indicates the top. Use tech screws supplied to secure filler. OEM fill and fast fill hoses can now be connected to new filler.
3. Install brass fittings into tank. P3 5/8 x 1/4 straight fitting goes into the socket adjacent to the filler neck, the P3 1/4 x 1/4 straight fitting goes into the socket in the expansion chamber. The 8mm pick up tube goes to the front of the two sockets on the lower level of the tank, the 1/4" BSP plug goes into the rear most socket. With the sender assembly installed in the tank, check OHMS readings by rolling the tank and recording results. **FULL** reading should be 90 OHMS, **EMPTY** reading should be 0 OHMS.
4. If the vehicle is fitted with stabilizer release cable, bend cable mounting brackets in towards chassis rail. There is a small gusset welded towards the RH rear of the tank location which has an 8mm hole drilled in it. Locate this hole and drill it out to 10mm, then place M10 x 30mm bolt in it. Locate hole that is in the top of rear chassis tube above the rear differential and drill hole directly below it. Install front

secondary bracket to existing 8mm drilled holes in chassis rail. Lift tank into position using M10 x 30mm bolt previously placed in corner gusset section as main locating point. Make sure tank is running as close as possible to RH chassis rail.

5. Check all fuel and brake lines are clear from rubbing on the tank. Clamp front of tank, drill holes and secure with M8 x 25mm bolts and nyloc nuts. Secure long rear bracket with M10 x 75mm bolt and Nyloc nut. (Due to chassis variations you may need to space the rear of the tank down slightly on some vehicles).
6. Fit steel fill pipe section in place, steel fill pipe is put into position from the forward side of the differential and fed backwards, not from the rear to the front. Connect auxiliary side of twin filler to steel fill pipe with 44mm ID hose bend. Connect other end of pipe to auxiliary tank with 400mm length of 38mm ID hose. Connect 1600mm length of 16mm hose from 16mm hose barb straight on auxiliary tank to new twin filler. Ensure this line has no low points in it.
7. Connect auxiliary tank vent hose and fuel transfer hose to their allocated fittings on the new twin filler. Finish connection of fuel pump to fuel pick up line with filter in between fuel pump and pick up. Connect fuel sender wires, cable tie all hoses and pipe work neatly in place. Fill with fuel and check system operation.

**NOTE: USE HIGH QUALITY SEALER ON ALL JOINTS AND FITTINGS. E.G. PERMATEX 3J**



## FITTING KIT CONTENTS FMSA

<b>Brass:</b> <ul style="list-style-type: none"> <li>○ 1 x P3 1/4 x 1/4 Straight</li> <li>○ 1 x P6 1/4 x 1/4 Elbow</li> <li>○ 2 x P6 5/8 x 1/4 Elbow</li> <li>○ 1 x P3 5/8 x 1/4 Straight</li> <li>○ 1 x P6 5/16 x 1/4 Elbow</li> <li>○ 1 x 8mm Fuel Pick Up</li> <li>○ 1 x 1/4" BSP Plug</li> </ul>	<b>Electrical:</b> <ul style="list-style-type: none"> <li>○ 1 x 3mm Two Core Wire @ 5000mm</li> <li>○ 1 x LRA-PG210 Switch/Gauge</li> <li>○ 1 x Red Insulated Terminal</li> <li>○ 3 x 3mm Heat Shrink Tube @ 25mm</li> <li>○ 3 x 6mm Blue Earth Eye</li> </ul>
<b>Bolts / Nuts:</b> <ul style="list-style-type: none"> <li>○ 5 x M5 x 8mm Pan Head (for sender)</li> <li>○ 1 x M10 x 75mm Bolt</li> <li>○ 1 x M10 x 30mm Bolt</li> <li>○ 1 x M10 Plain Nut</li> <li>○ 2 x M10 Nyloc Nut</li> <li>○ 2 x M10 Washers</li> <li>○ 6 x 8mm Tech Screws</li> <li>○ 2 x M8 x 25mm Bolts</li> <li>○ 4 x M8 Nyloc Nuts</li> <li>○ 6 x M8 Flat Washers</li> </ul>	<b>Misc Parts:</b> <ul style="list-style-type: none"> <li>○ 1 x Twin Filler #TFGQAUX</li> <li>○ 1 x Fuel Cap SC91</li> <li>○ 1 x Front Secondary Bracket with Mounting Plate and Bolts</li> <li>○ 1 x Fill Pipe #FPGQAUX</li> </ul>
<b>Hose Clamps:</b> <ul style="list-style-type: none"> <li>○ 8 x 1/4" Hose Clamps</li> <li>○ 4 x 5/8" Hose Clamps</li> <li>○ 4 x 1 1/2" Hose Clamps</li> </ul>	<b>Cable Ties:</b> <ul style="list-style-type: none"> <li>○ 10 x 7" Cable Ties</li> <li>○ 5 x 11" Cable Ties</li> <li>○ 2 x 14" Cable Ties</li> </ul>
<b>Sender:</b> <ul style="list-style-type: none"> <li>○ 1 x Fuel Sender Unit 0-90 OHM</li> </ul>	<b>Pumps &amp; Filters:</b> <ul style="list-style-type: none"> <li>○ 1 x Fuel Pump</li> <li>○ 1 x Z14 Fuel Filter</li> </ul>

Hose:	6 Pages of Fitting Instructions Consisting of:
1 x 38mm Fuel Hose @ 400mm 1 x 44mm Fuel Hose 90° bend 1 x 8mm Fuel Hose @ 600mm 1 x 8mm Fuel Hose @ 1200mm 1 x 16mm CMP @ 430mm 1 x 16mm CMP Hose @ 1600mm 1 x 6mm CMP Hose @ 1700mm	<ul style="list-style-type: none"><li>○ 2 x Pages Fitting Instructions</li><li>○ 2 x Pages Fitting Kit Contents</li><li>○ 1 x Page WDSGPG210 Diagram</li><li>○ 1 x Installation Diagram</li></ul>

Kit Packed By \_\_\_\_\_

Checked By \_\_\_\_\_

# GQ SWB Auxiliary

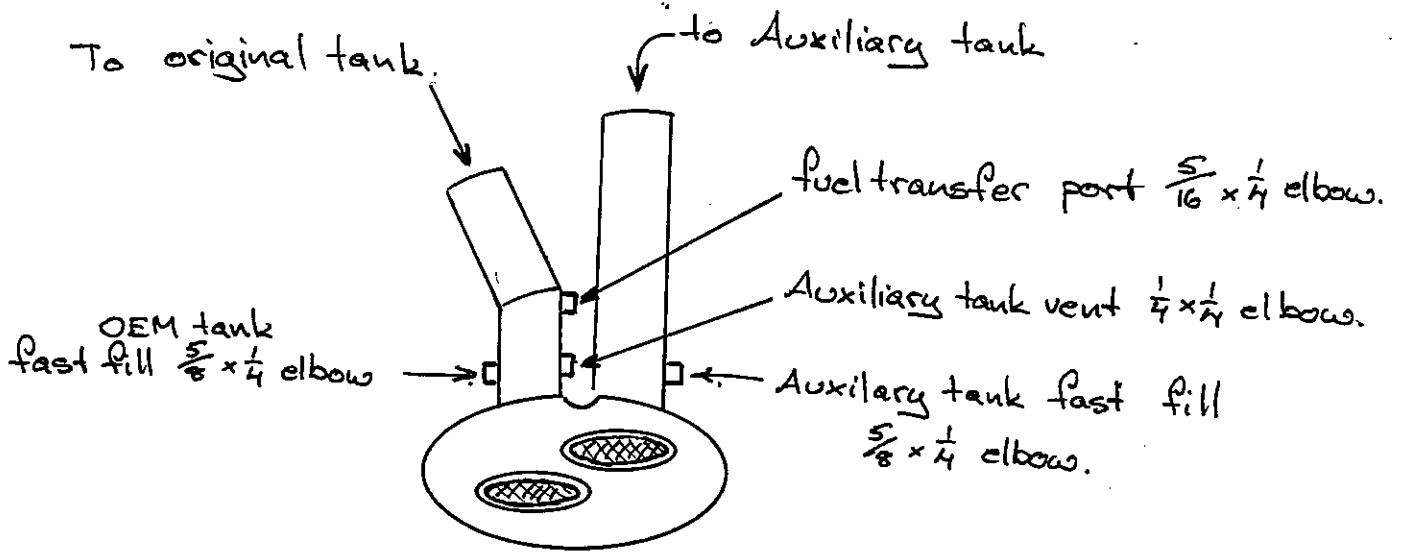

twin filler assembly. Part # TFGQAux

New twin filler installed to filler recess and showing suggested points for Tech Screws.

Tech Screws.

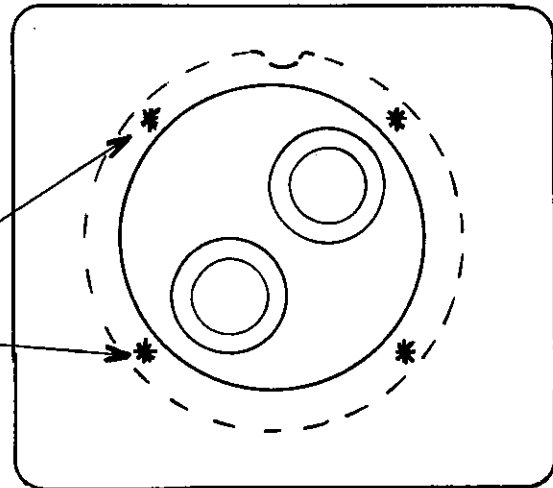

front →

front secondary bracket

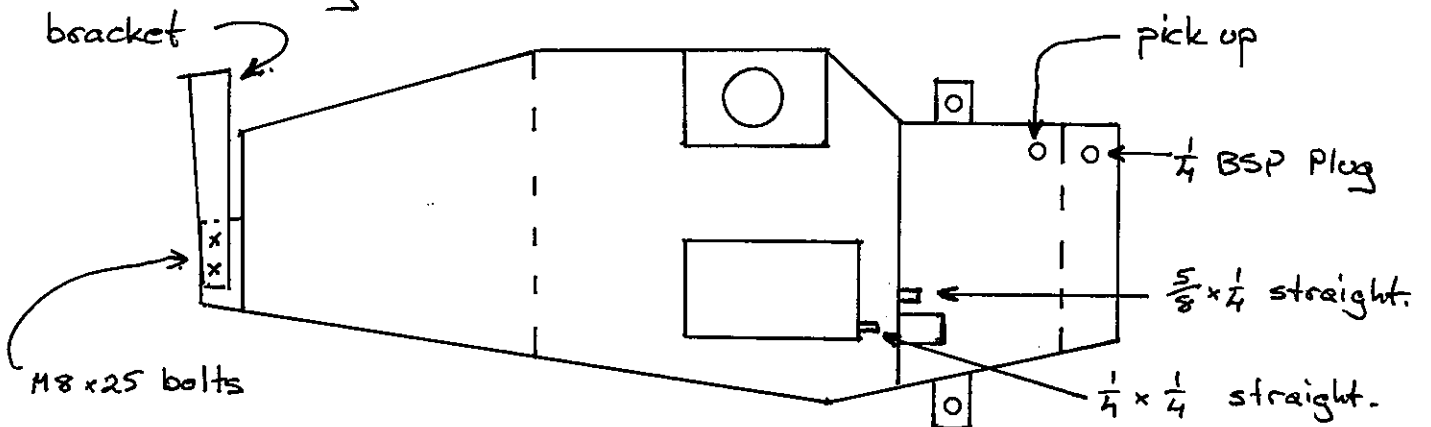

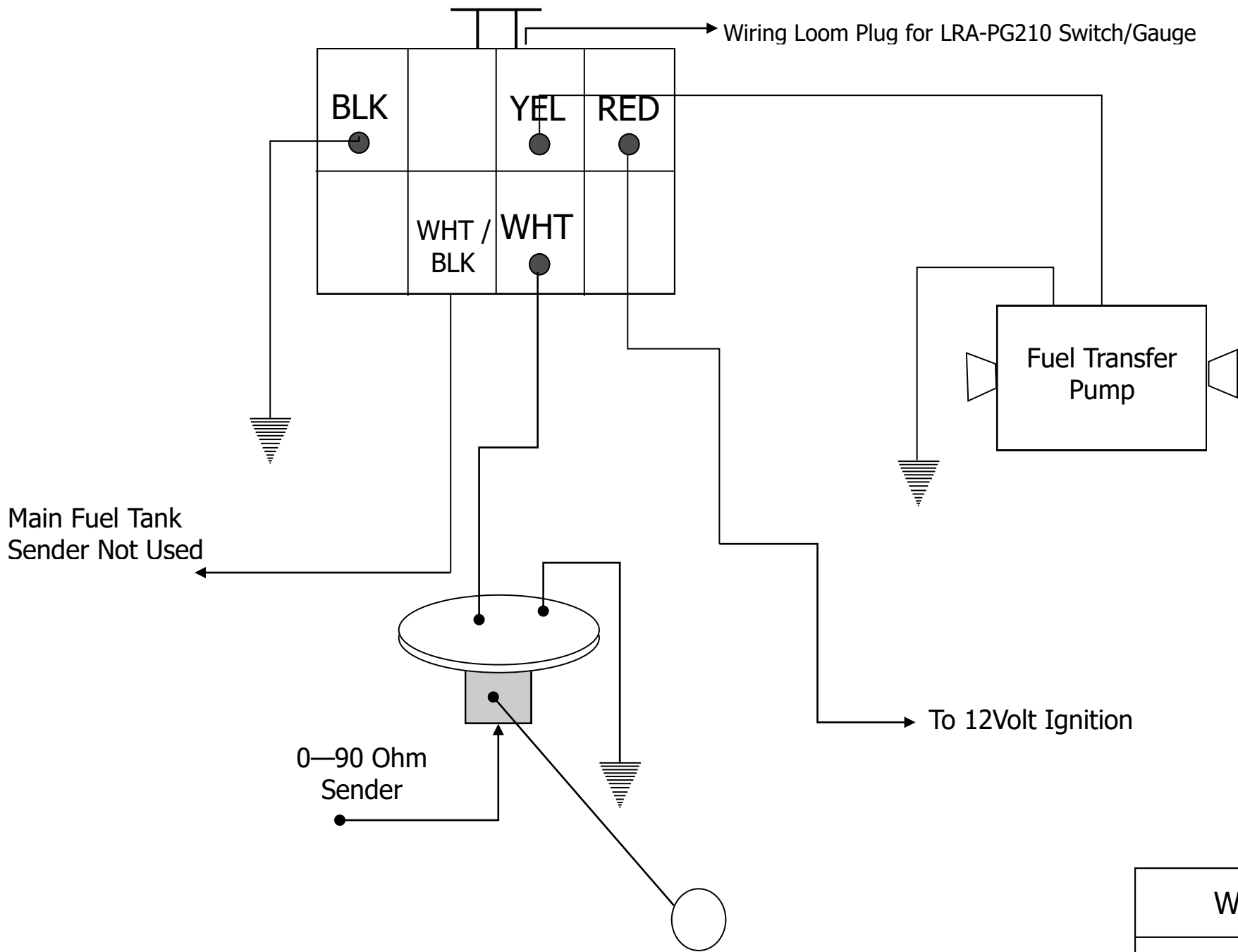

WDSGPG210