



## Installation Instructions for TLC78V8PA Toyota Landcruiser 78 Series Troopy 90lt Auxiliary Tank

IMPORTANT: This tank fitment requires clear access to the floor pan!

This auxiliary tank fits forward of the rear axle on the left hand side of the drive shaft and steps up and over the drive shaft to the right hand side. This tank requires the exhaust to be modified by changing the muffler to an oval shape 2 1/4" off set centre type fitted vertically close to the LHS chassis rail.

A combination switch/gauge will be located into a suitable position in the dash. When the switch is in operation an **ORANGE** light will be ON, indicating that the transfer pump is in operation. A series of lights will also indicate the fuel level. ALL **GREEN** lights on showing FULL, one **RED** flashing light showing EMPTY.

**NOTE: DO NOT OPERATE THE TRANSFER PUMP FOR EXTENDED PERIODS OF TIME  
WHILST THE AUXILIARY TANK IS EMPTY OR PUMP DAMAGE WILL RESULT!**

1. Carry out wiring of PG200 switch gauge unit. Suggested switch location is in the large rectangle blank on the RHS of the dash. A 12volt ignition power source can be found under the R/H kick panel (Blue wire). Run the twin core under the scuff plates and out through a small grommet in the floor pan. Prepare wiring for connection to the sender unit and fuel transfer pump.
2. Remove the original filler neck from the vehicle. Trim body panel for clearance to auxiliary tank fast fill hose as per Pic 1. Screw the fittings into the new twin filler neck as per Pic 2. Fit the 750mm long 12mm auxiliary tank fast fill hose and the 450mm long 12mm main tank fast fill vent hose. Along with the 650mm length of 8mm hose to the new twin fill neck and fit to vehicle with the original gasket and screws.
3. Disconnect hand brake cable from rear axle housing and remove rubber guide mounts and cable guide mount from cross member from the cable.

4. Remove rear section of drive shaft taking note of spline alignment for later refitting. Remove muffler. (This will need to be replaced with an oval shaped muffler positioned vertically close to L/H chassis rail). Refer Pic 3
5. Assemble fittings into tank. P6 ½" x 3/8" Elbow in the front of the tank pointing in the same direction as the filler. P6 5/16" x ¼" Elbow in the rear of the tank pointing to the RHS and the P3 5/16" x 1/8" into the expansion box on the top of the tank. Fit the 1000mm length of 8mm hose to the expansion box fitting.
6. Lift tank into position, connect the sender unit wire, keeping the RHS of the tank about 100mm away from the wheel arch body flange. The brackets on the tank will then line up with the low section of the ribs in the floor pan, allowing you to mount to the floor using reinforcing plates, M10 x 30mm bolts and Nyloc nuts.
7. Mount fuel transfer pump in a suitable location. Connect the fuel pick up to the inlet side of the pump and the outlet side of the pump goes to the 12mm x 8mm Tee fitted to the fast fill vent from the rear tank. Ref Pic 4
8. Connect the 8mm hose from the expansion box on the auxiliary tank to the P14 5/16" Tee fitted to the vent line. Ref Pic 5
9. Connect the Fast fill vent hose from the twin filler to the P6 ½" x 3/8" elbow on the auxiliary tank. Use the 330mm length of 38mm hose to connect the filler to the auxiliary tank.
10. Re-fit drive shaft, refit hand brake cable by threading cable through tube in centre of tank and reconnect to brakes and axle housing.
11. Fill tank with fuel, check all hoses and fittings for leaks and check operation of fuel gauge and transfer pump.



## FITTING KIT CONTENTS TLC78V8PA

<b>Brass</b> <ul style="list-style-type: none"> <li>○ 2 x P6 5/16 x 1/4 (8mm Elbow)</li> <li>○ 3 x P6 1/2 x 3/8 (12mm Elbow)</li> <li>○ 1 x P3 5/16 x 1/8 (8mm Straight)</li> <li>○ 1 x P14 5/16 Tee Piece</li> <li>○ 1 x 12mm x 8mm Reducing Tee</li> </ul>	<b>Electrical</b> <ul style="list-style-type: none"> <li>○ 1 x 3mm Two Core Wire @ 4000mm</li> <li>○ 2 x Blue 6mm Earth Eye Terminals</li> <li>○ 1 x Blue 8mm Eye Terminal</li> <li>○ 1 x Red Insulated Terminals</li> <li>○ 4 x 3mm Heat Shrink @ 25mm Long</li> <li>○ 1 x LRA-PG210 Switch Gauge</li> <li>○ 1 x Fuse Holder</li> <li>○ 1 x 10 AMP Fuse</li> <li>○ 1 x 16mm Conduflex @ 600mm</li> <li>○ 1 x 6mm Conduflex @ 1400mm</li> </ul>
<b>Bolts / Nuts</b> <ul style="list-style-type: none"> <li>○ 5 x M5 x 8mm Pan Head Screws</li> <li>○ 4 x M10 x 30mm Bolts</li> <li>○ 4 x M10 Nyloc Nuts</li> <li>○ 4 x M10 Washers</li> <li>○ 2 x 25mm Tek Screws</li> </ul>	<b>Misc Parts</b> <ul style="list-style-type: none"> <li>○ 4 x 40 x 200 x 5mm Reinforcing Plates</li> <li>○ 1 x Twin Filler Neck P/No TFTLC78V8PA</li> <li>○ 1 x Fuel Pump Mounting Bracket</li> </ul>
<b>Hose Clamps</b> <ul style="list-style-type: none"> <li>○ 10 x 1/4" Hose Clamps</li> <li>○ 6 x 1/2" Hose Clamps</li> <li>○ 2 x 1 1/4" Hose Clamps</li> </ul>	<b>Cable Ties</b> <ul style="list-style-type: none"> <li>○ 15 x 7" Cable Ties</li> <li>○ 3 x 11" Cable Ties</li> </ul>
<b>Hose</b> <ul style="list-style-type: none"> <li>○ 1 x 38mm Fuel Hose @ 330mm</li> <li>○ 1 x 12mm CMP Hose @ 450mm</li> <li>○ 1 x 12mm CMP Hose @ 750mm</li> <li>○ 1 x 8mm Fuel Hose @ 1500mm</li> <li>○ 1 x 8mm Fuel Hose @ 1000mm</li> <li>○ 1 x 8mm Fuel Hose @ 650mm</li> </ul>	<b>7 x Pages Instructions Consisting Of:</b> <ul style="list-style-type: none"> <li>○ 2 x Page Fitting Instructions</li> <li>○ 1 x Page Fitting Kit Contents</li> <li>○ 1 x WDSGPG210 Wiring Diagram</li> <li>○ 3 x Pages Installation Pictures 1-5</li> </ul>
<b>Sender</b> <ul style="list-style-type: none"> <li>○ 1 x 0-90 OHM Sender Set Up &amp; Tested in Tank c/w 400mm Earth Lead</li> </ul>	<b>Filters &amp; Pumps</b> <ul style="list-style-type: none"> <li>○ 1 x Fuel Pump</li> </ul>

Kit Packed By \_\_\_\_\_

Kit Checked By \_\_\_\_\_

TLC78V8PA Fitting Instruction Photos

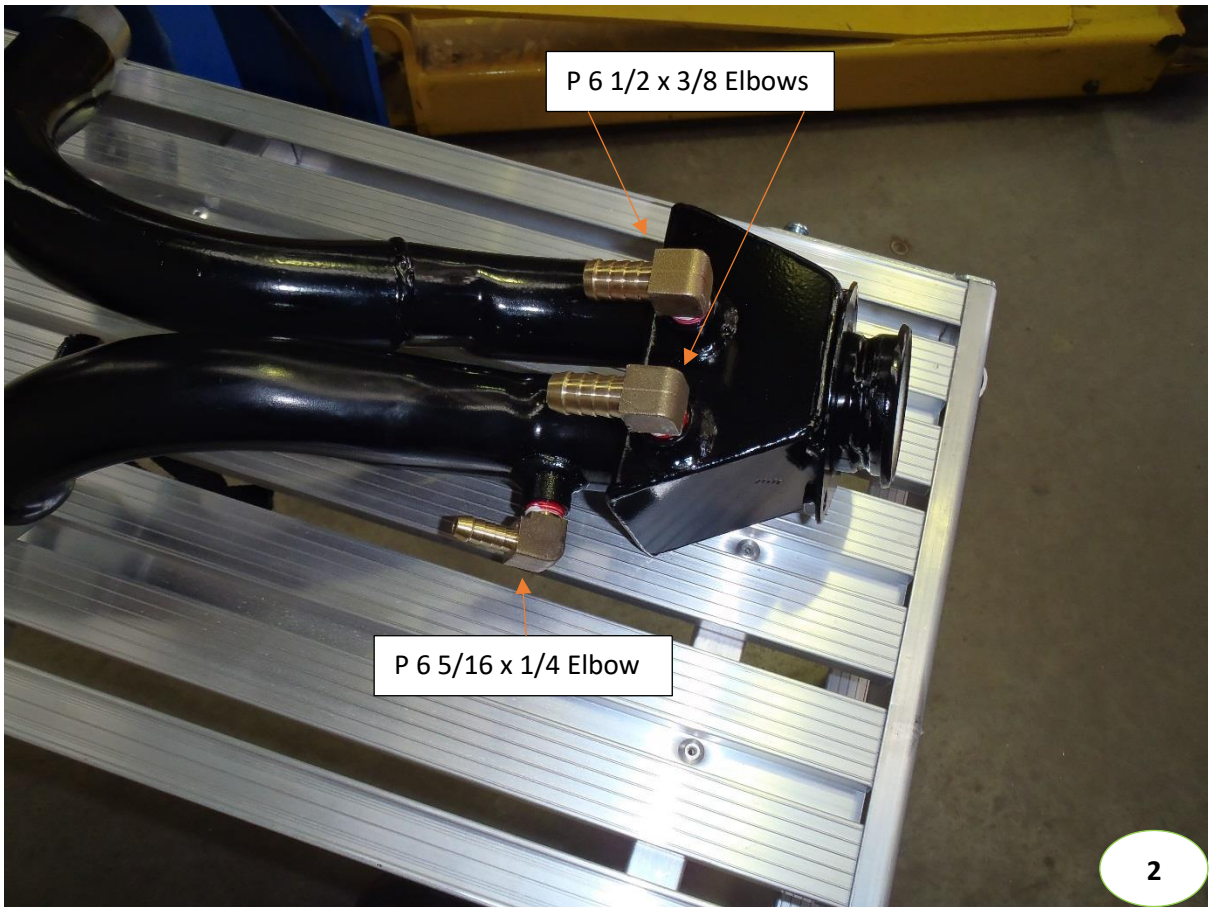

TLC78V8PA Fitting Instruction Photos

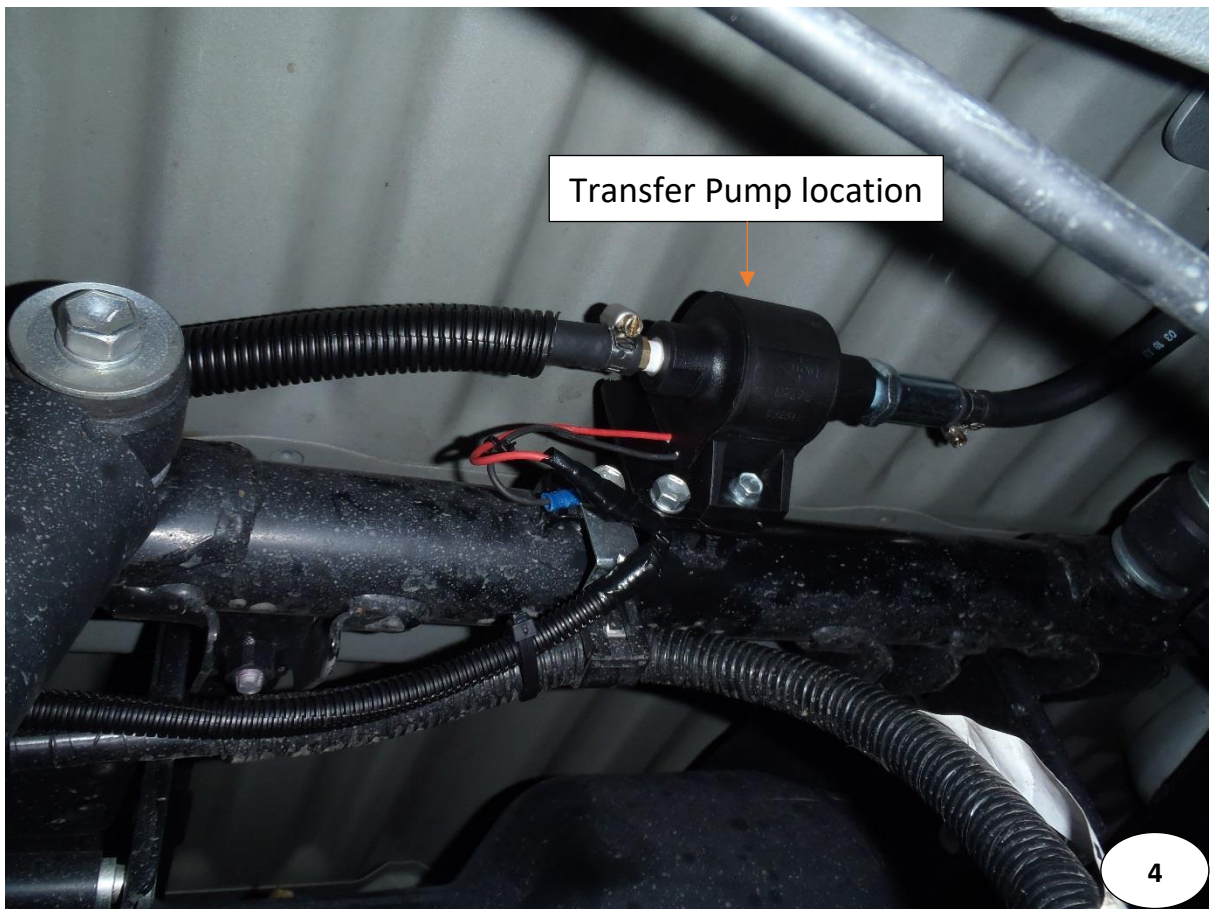

TLC78V8PA Fitting Instruction Photos



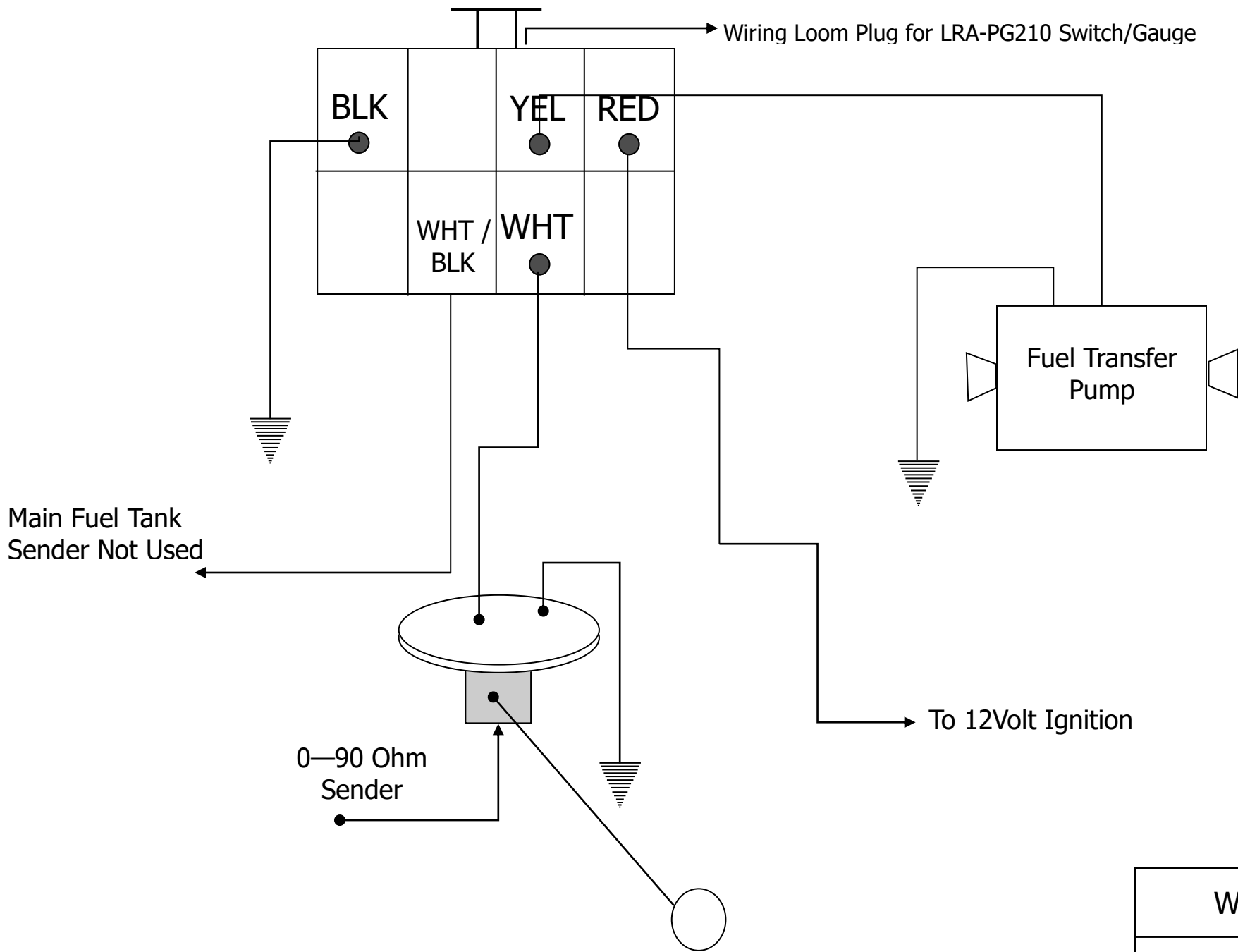

WDSGPG210