



Installation Instructions for TLCFJCRUISERA-90 Toyota Landcruiser FJ Cruiser 90lt Auxiliary Tank

This Auxiliary Fuel Tank fits up under the rear of the vehicle. The standard filler neck is replaced with a new twin filler neck.

Fuel is transferred via an electric pump that will pump fuel from the auxiliary tank into the OEM tank. A combination switch/gauge will be located into a suitable position in the dash. When the switch is in operation an orange light will be on, indicating that the transfer pump is in operation. A series of lights will also indicate fuel level. All green lights on showing full, one red light flashing showing empty.

(DO NOT OPERATE TRANSFER PUMP WITH NO FUEL IN AUXILIARY TANK OR PUMP FAILURE WILL OCCUR).

1. Select a suitable location for the switch gauge unit. Run the twin core cable under the R/H scuff plates and under the rear scuff plate and out through the grommet in the jack storage area. A 12volt ignition source can be found near the fuse panel on the RHS of the steering column. (Blue / Yellow).
2. Remove the LHR wheel arch cover and remove the standard fill pipe and cut as per diagram **(Refer Pics A & B)**. Fit 550mm length of 12mm hose to the fast fill vent pipe and refit fill pipe assembly to vehicle. Screw brass fittings into the filler neck as per diagram **(Refer Pics C & D)** and refit to vehicle. Cut the two brackets off the front cross member **(Refer Pic E)**. Unbolt the fuel pump control module and replace the mounting bracket with the new bracket from the fitting kit **(Refer Pic F)**.
3. Unclip the wiring loom from the LHS rear of the chassis rail and drill out the slotted holes to 12.5mm on both sides. Bolt the rear mounting bar in place with M12 x 30mm bolts with straps.
4. Mount the fuel transfer pump to the wheel arch are **(Refer Pic G)** and complete wiring. Screw the brass into the tank. P6 5/16 x 1/4 elbow goes into the top of the tank pointing forward. P3 1/2 x 3/8 straight goes into the fitting next to the filler neck. Fit the Roll Over valve and grommet pointing forward and fit 1100mm length of 6mm hose to this valve.

5. Jack tank into position and fit 140mm length of 35mm hose to the filler neck and guide onto the fill pipe as the tank goes into position. Secure the front of the tank with U bolts washers and Nyloc nuts (be careful not to pinch wiring under the LHF U Bolt). Secure the rear of the tank with M12 x 30mm Bolts washers and Nyloc nuts. Connect remaining hoses and check over all hose and fittings. Cut a small section from the wheel arch cover **(Refer Pic H)**. Refit cover and warm with heat gun mould to shape.



FITTING KIT CONTENTS TLCFJCRUISERA-90

Brass: <ul style="list-style-type: none"> ○ 1 x P6 1/4 x 1/8 Elbow ○ 1 x P6 5/16 x 1/8 Elbow ○ 1 x P6 5/16 x 1/4 Elbow ○ 2 x P6 1/2 x 3/8 Elbows ○ 1 x P3 1/2 x 3/8 Straight 	Electrical: <ul style="list-style-type: none"> ○ 1 x LRA-PG210 Switch Gauge Unit ○ 1 x 3mm two core @ 5000mm ○ 1 x 4mm Single Core Blue Wire @ 300mm ○ 1 x 5AMP Fuse ○ 1 x Fuse Holder ○ 2 x Fuse Holder Terminals ○ 1 x Red Insulated Terminal ○ 1 x Red Eye Terminal ○ 2 x Blue 6mm Eye Terminal ○ 3 x 3mm Shrink Tube @ 30mm
Bolts / Nuts: <ul style="list-style-type: none"> ○ 1 x M6 x 20 Washer ○ 1 x M6 Nyloc Nut ○ 6 x M10 x 25 Washers ○ 6 x M10 Nyloc Nuts ○ 6 x M12 Nyloc Nuts ○ 2 x M12 x 30 Bolts ○ 8 x M12 H/Duty Washers 	Misc Parts: <ul style="list-style-type: none"> ○ 1 x Twin Filler ○ 1 x Rear Mounting Bar ○ 1 x Fuel Pump Control Bracket ○ 1 x Roll over Valve ○ 1 x LRA-FTG-2 Grommet ○ 3 x M10 U Bolts 70 x 100 ○ 4 x M12 x 30mm Bolts with 150mm Straps
Hose Clamps: <ul style="list-style-type: none"> ○ 8 x 1/4" Hose Clamps ○ 4 x 1/2" Hose Clamps ○ 4 x 1 1/4" Hose Clamps 	Hose: <ul style="list-style-type: none"> ○ 1 x 6mm Hose @ 1100mm ○ 1 x 8mm Hose @ 1000mm ○ 1 x 8mm Hose @ 450mm ○ 1 x 35mm Hose @ 140mm ○ 1 x 35mm Hose @ 80mm ○ 1 x 12mm NTP Hose @ 620mm ○ 1 x 12mm NTP Hose @ 550mm

Pumps & Filters:	Cable Ties:
<ul style="list-style-type: none"> ○ 1 x Fuel Pump & Filter ○ 1 x Fuel Pump Mounting Plate 	<ul style="list-style-type: none"> ○ 3 x 7" Cable Ties ○ 5 x 11" Cable Ties
Sender:	7 Pages of Fitting Instructions Consisting of:
<ul style="list-style-type: none"> ○ 1 x 0-90 OHM Sender with 700mm Earth, Installed Using: <ul style="list-style-type: none"> - 5 x M5 x 10 Pan Heads - 5 x M5 Spring Washers 	<ul style="list-style-type: none"> ○ 2 x Pages Fitting Instructions ○ 2 x Pages Fitting Kit Contents ○ 2 x Pages Reference Pictures (A-H) ○ 1 x Page WDSGPG210 Wiring Diagram

Kit Packed By _____

Checked By _____

TLCFJCRUISERA FITTING INSTRUCTION PHOTOS

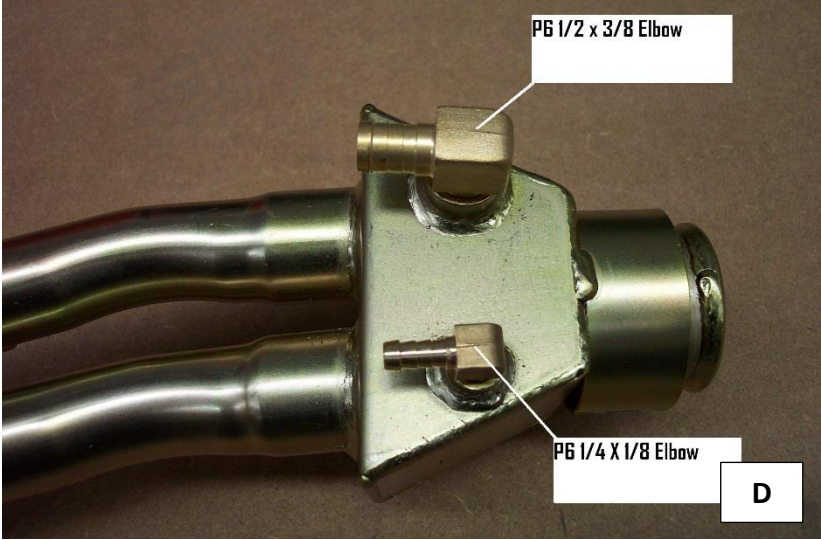
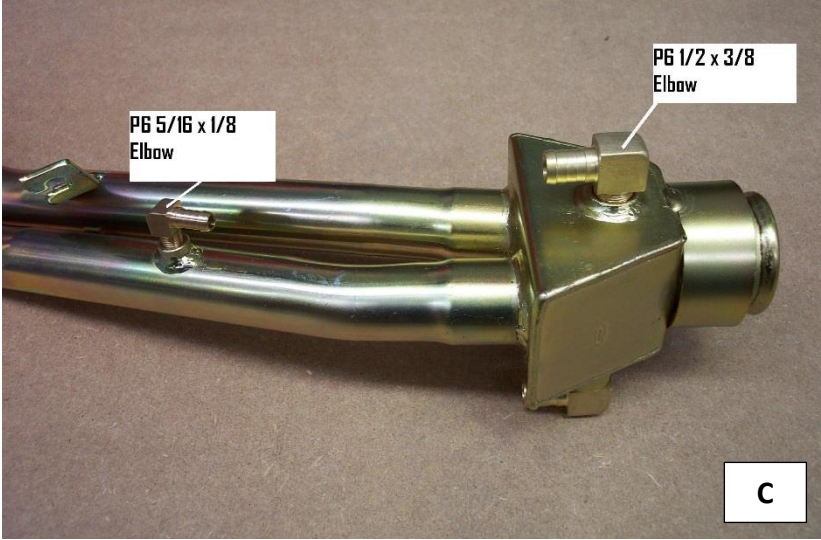
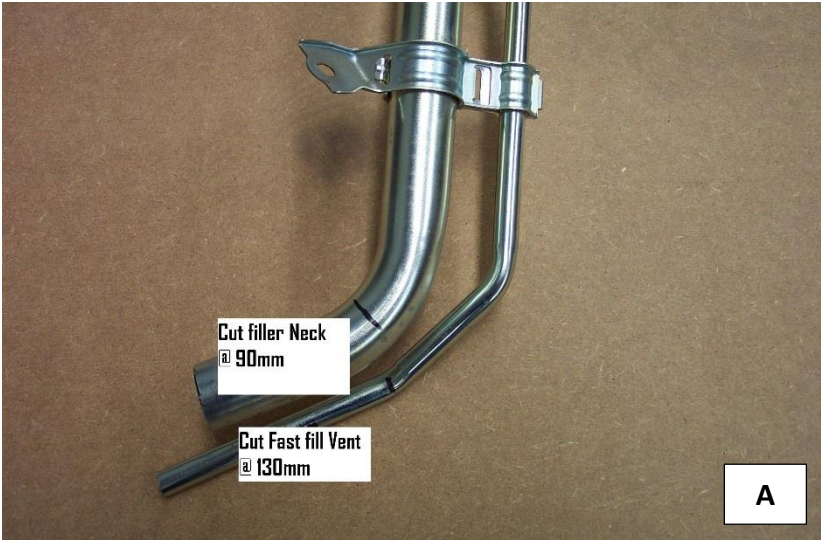

TLCFJCRUISERA FITTING INSTRUCTION PHOTOS

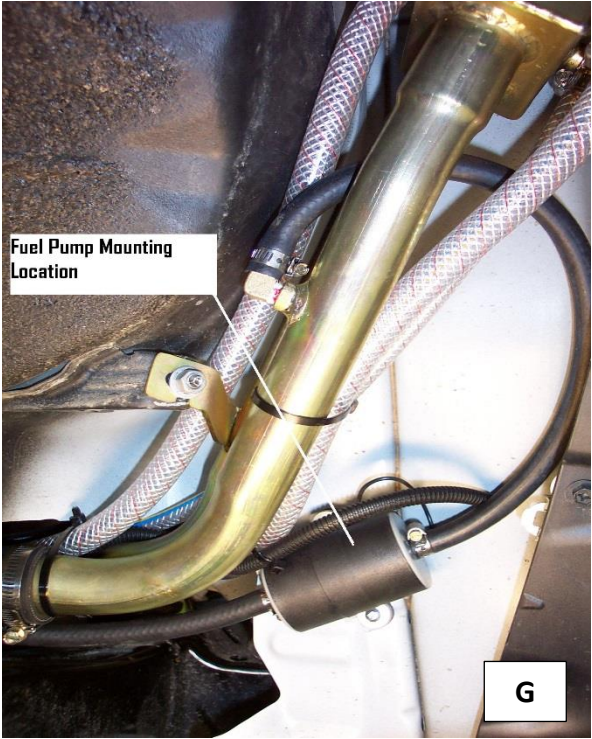
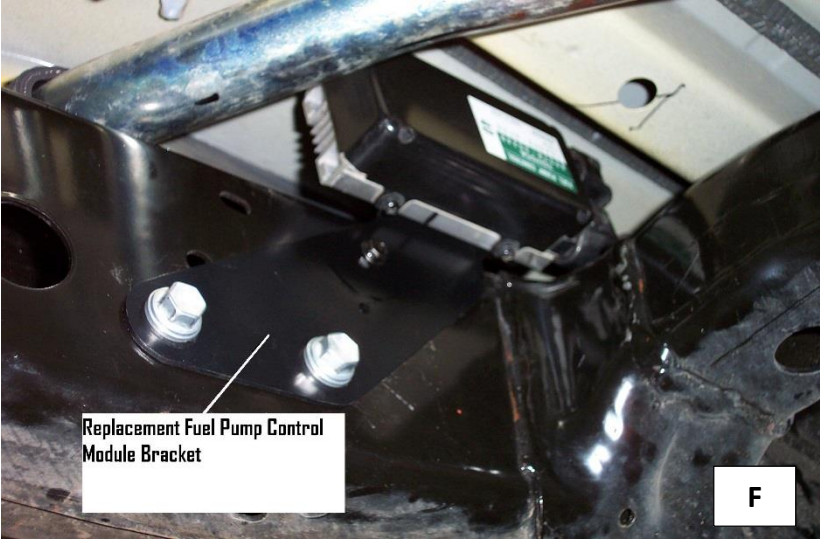
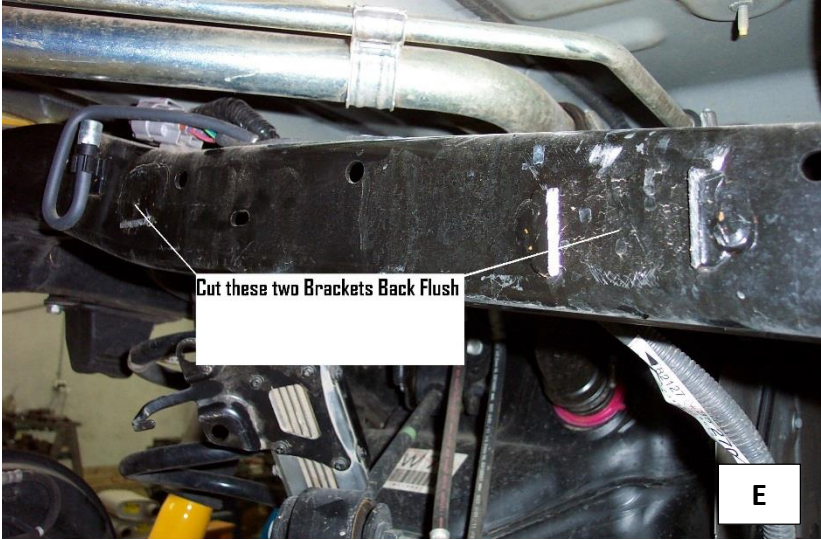

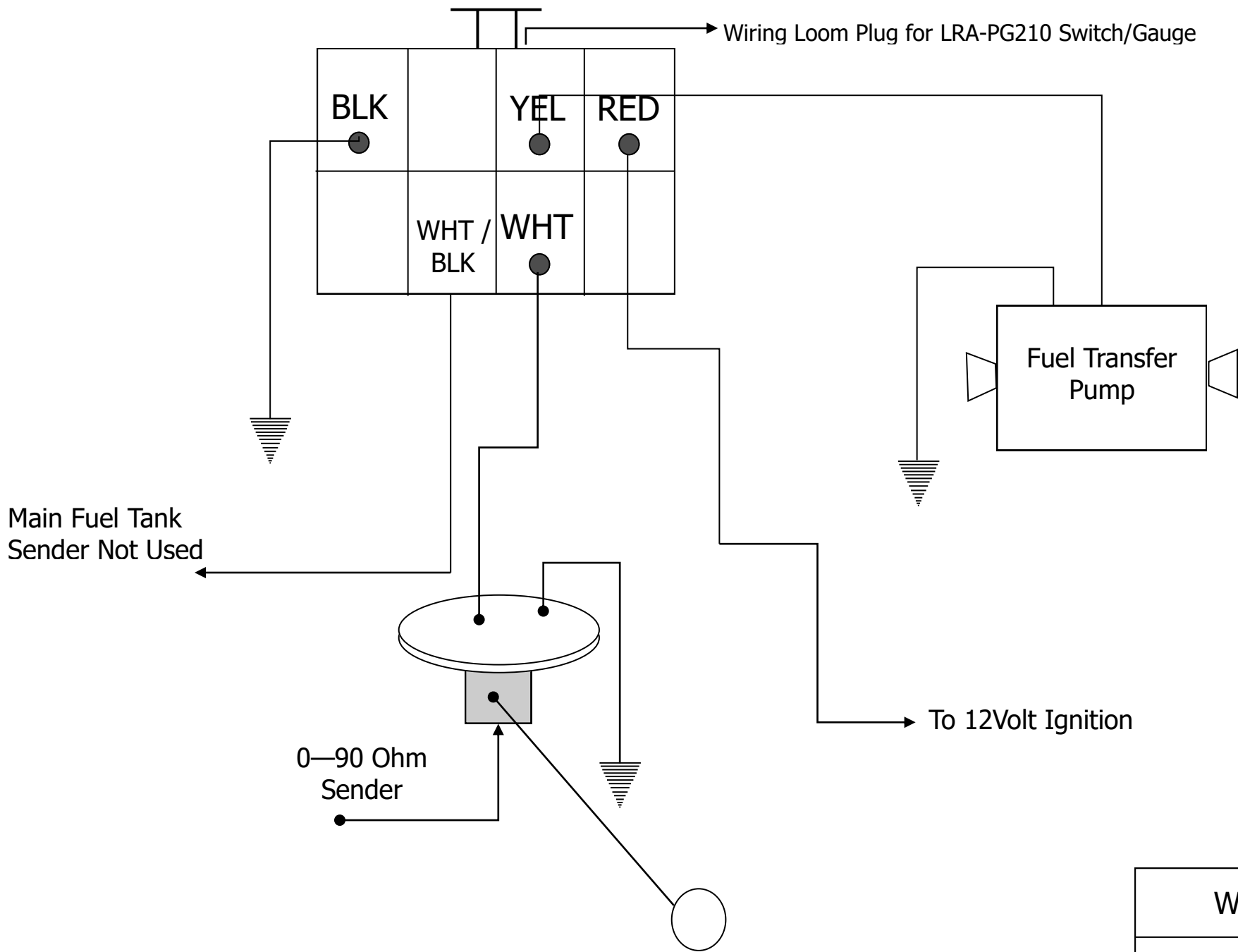

WDSGPG210