



**Installation Instructions for TLC78V8SSW
Toyota Landcruiser 90L Stainless Steel
Water Tank to suit VDJ78 Series Troop Carrier**

This water tank fits forward of the rear axle on the LHS of the drive shaft and steps up and over the drive shaft to the RHS. This tank requires clear floor access to the inside of the vehicle to complete installation. It also requires the exhaust muffler to be changed or modified. The filler is mounted into the right-hand side panel.

1. Disconnect the hand brake cable from the rear diff assembly and cut the rubber guide mounts from the cable, leaving part of the rubber around the metal lug of the cable to stop it chaffing in the tube of the water tank. Undo the brake proportioning valve arm from the rear diff. Remove the rear drive shaft, taking note of spline alignment for later re-fitment.
2. Remove the muffler. This will need to be changed to an oval type of muffler fitted vertically close to the LH chassis rail. (The tank sits approximately 200mm from the LH chassis rail)
3. Cut an 85mm \varnothing hole into the panel to the rear of the fuel filler door (**Refer Pic A**). Cut a 50mm and 25mm \varnothing holes into the inner panel for the fill and vent hoses as (**Refer Pic B**). Mount the water filler with 3 x M5 x 12mm C/S Screws Nyloc nuts and washers.
4. Assemble the fittings in water tank as show in the supplied fittings diagram.
5. Lift the tank into position and align to the low rib in the floor pan. Drill the mounting holes and fit 200mm long reinforcing plates from inside and M10 x 30mm Bolts and Nyloc Nuts. (Tank should be about 100mm away from the RHS wheel arch flange).
6. Connect the water tank outlet at the back of the tank to the inlet of your water pump. Connect the 700mm length of 10mm vent line from the tank through the grommet in the inner panel and up to the filler neck. Use the 160mm and 470mm lengths of 25mm fill hose with the E10 elbow to connect the filler to the tank (**Refer Pic C & D**)
7. Refit the drive shaft. Refit the hand brake cable by threading cable through the 50mm tube in the center of tank and re-connect to diff assembly. Refit the brake proportioning valve arm to diff.



FITTING KIT CONTENTS TLC78V8SSW with RHS Panel Mount Filler

Updated 8/22

| | |
|---|---|
| Brass: | Electrical: |
| <ul style="list-style-type: none"> ○ 1 x P6 1/2 x 1/4 12mm Elbow ○ 1 x P6 1/4 x 3/8 10mm Elbow ○ 1 x 1/4" Plug | |
| Bolts / Nuts: | Misc Parts: |
| <ul style="list-style-type: none"> ○ 4 x M10 x 30mm Bolts ○ 4 x M10 Nyloc Nuts ○ 4 x M10 Washers ○ 1 x TEK Screw ○ 3 x M4 x 20 Cap Screws ○ 3 x M4 Washers ○ 3 x M4 Nuts | <ul style="list-style-type: none"> ○ 1 x E10 1" Elbow ○ 1 x Panel Mount Filler with 90-Degree Outlet ○ 1 x WG10 Grommet ○ 1 x 25mm Fill Hose Grommet ○ 4 x 40mm x 200mm x 5mm Reinforcing Plates |
| Hose Clamps: | Cable Ties: |
| <ul style="list-style-type: none"> ○ 2 x 3/8" Hose Clamps ○ 4 x 1" Hose Clamps ○ 1 x 13mm P Clip | <ul style="list-style-type: none"> ○ 1 x 7" Cable Ties |
| Sender: | Pumps & Filters: |
| | |
| Hose: | 4 Pages of Fitting Instructions Consisting of: |
| <ul style="list-style-type: none"> ○ 1 x 25mm Water Fill Hose @ 160mm ○ 1 x 25mm Water Fill Hose @ 470mm ○ 1 x 10mm CMP Hose @ 700mm | <ul style="list-style-type: none"> ○ 1 x Page Fitting Instructions ○ 1 x Page Fitting Kit Contents ○ 1 x Page Fittings Diagram ○ 1 x Page Installation Photos |

Kit Packed By _____

Checked By _____

P6 1/2x1/4 elbow.
12mm hose to pump.

1/8 BSP
plug.

P6 3/8x1/4 elbow.
10mm filler vent line.

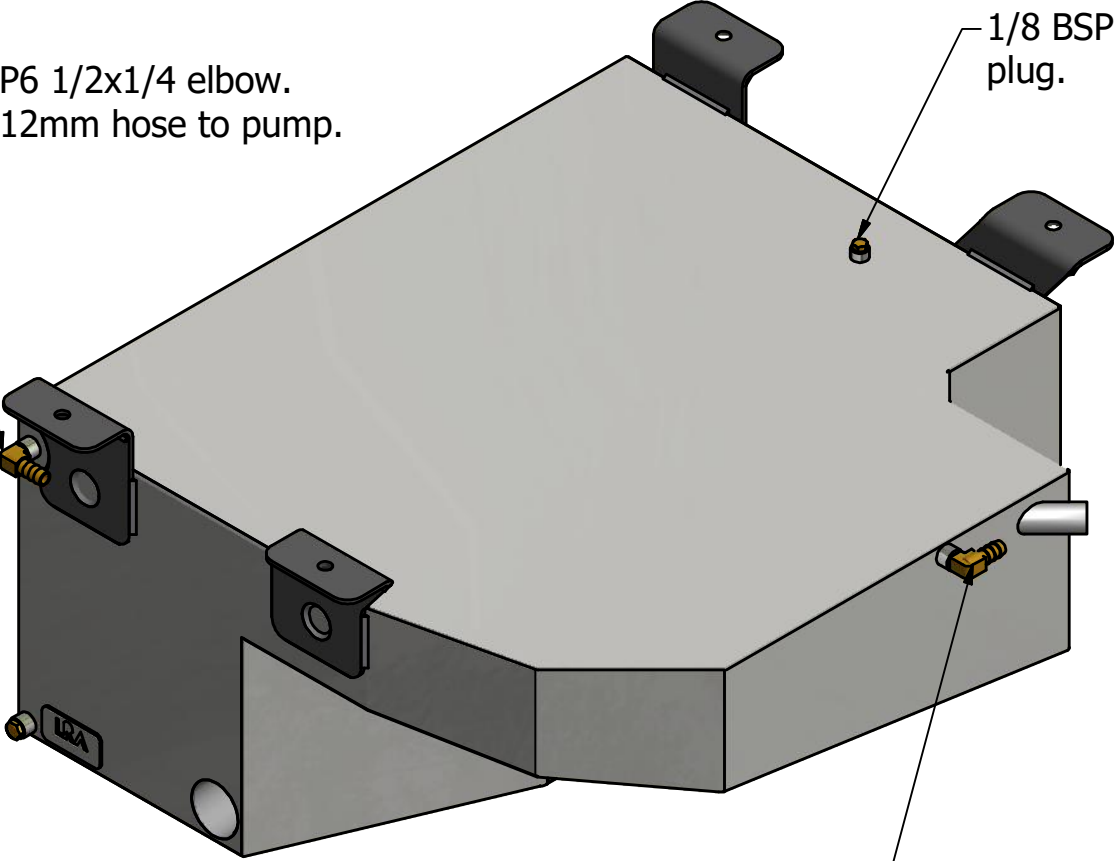

THIS DRAWING REMAINS THE PROPERTY OF
LONG RANGE AUTOMOTIVE AND IS NOT TO BE DUPLICATED
WITHOUT PERMISSION

TLC78V8SSW

18/2/2022

Toyota Landcruiser 78series 2007-
V8 diesel troop carrier. 90ltr centre
water tank.

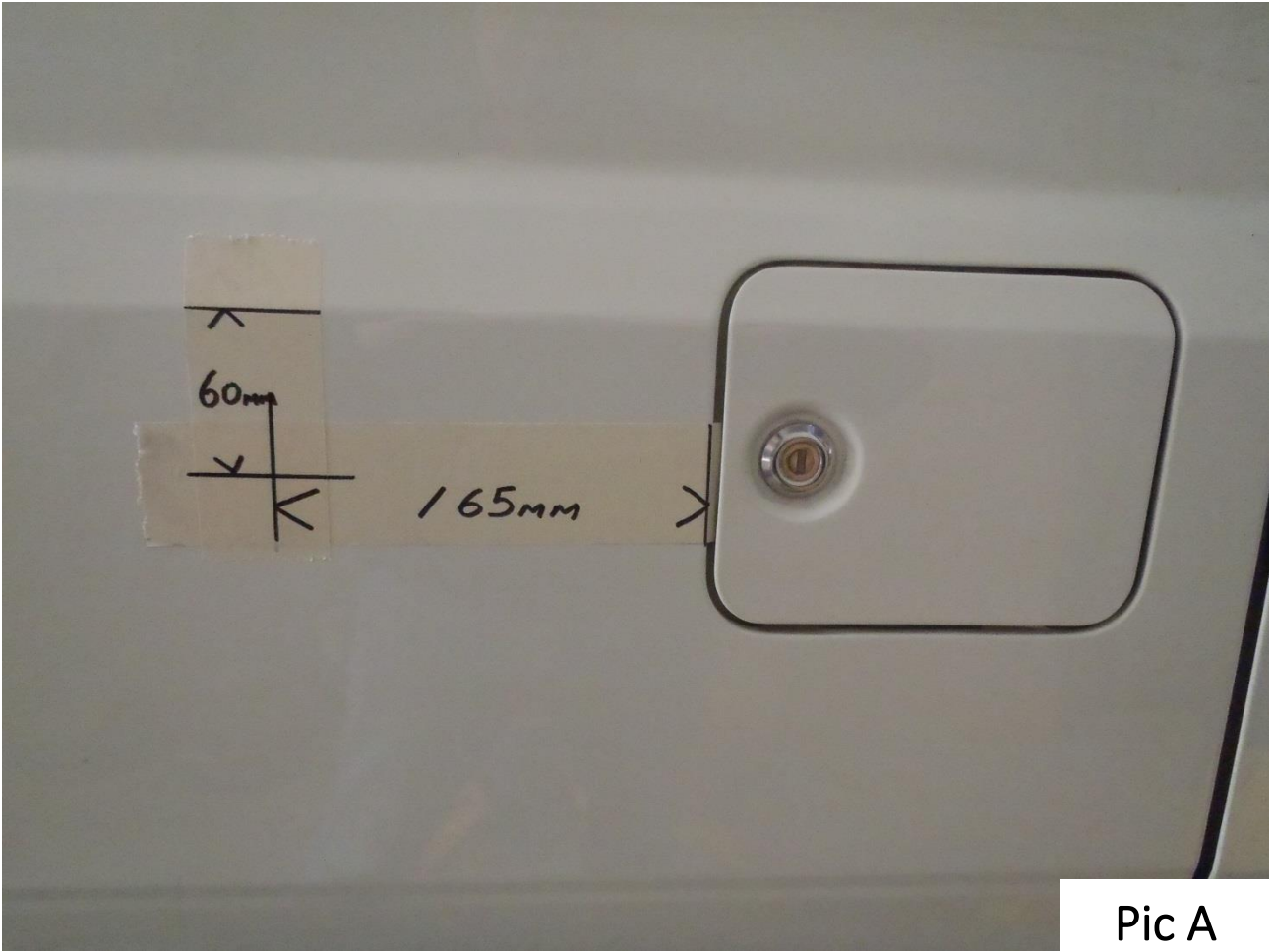

Pic A

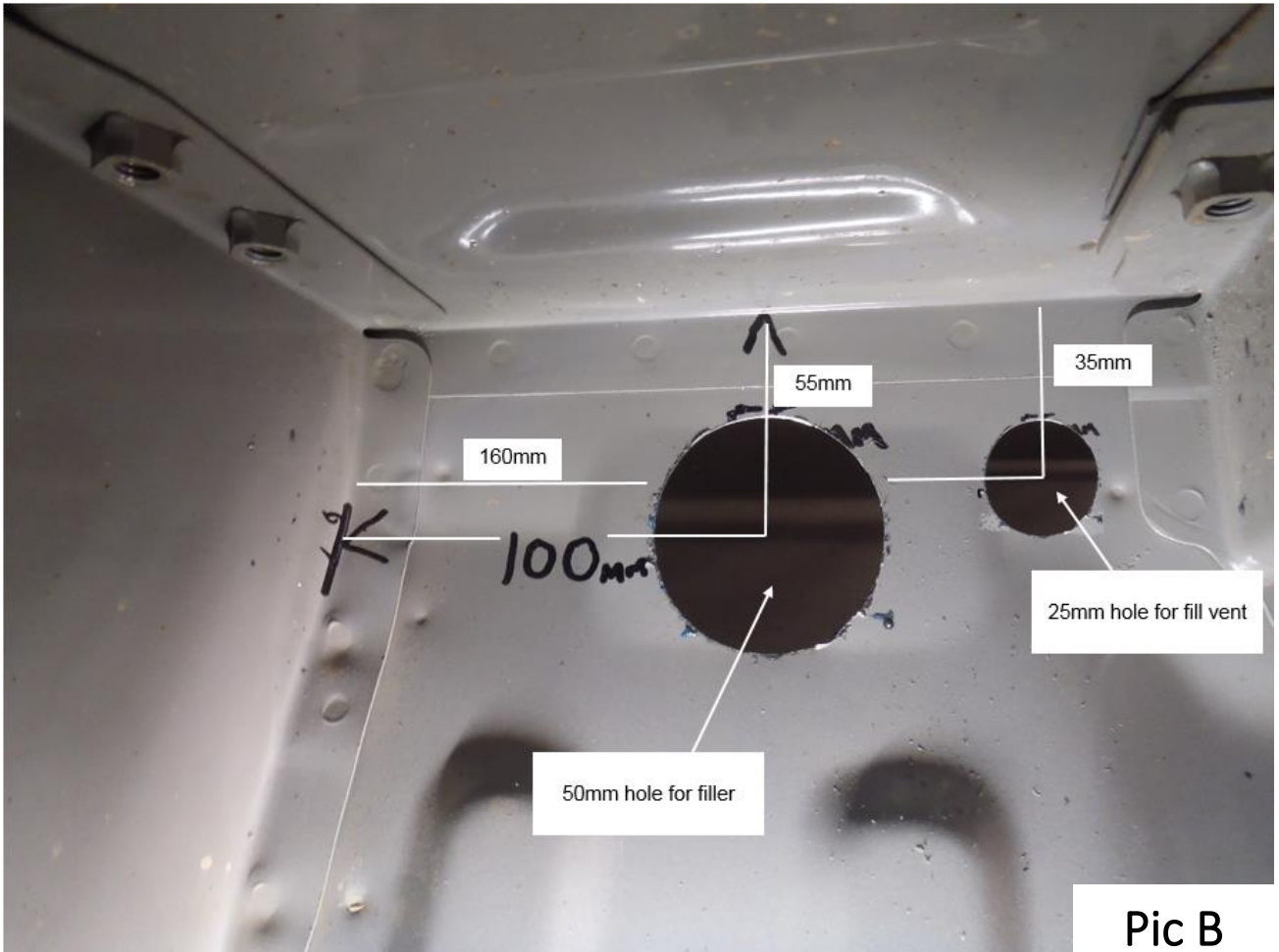

Pic B



Pic C

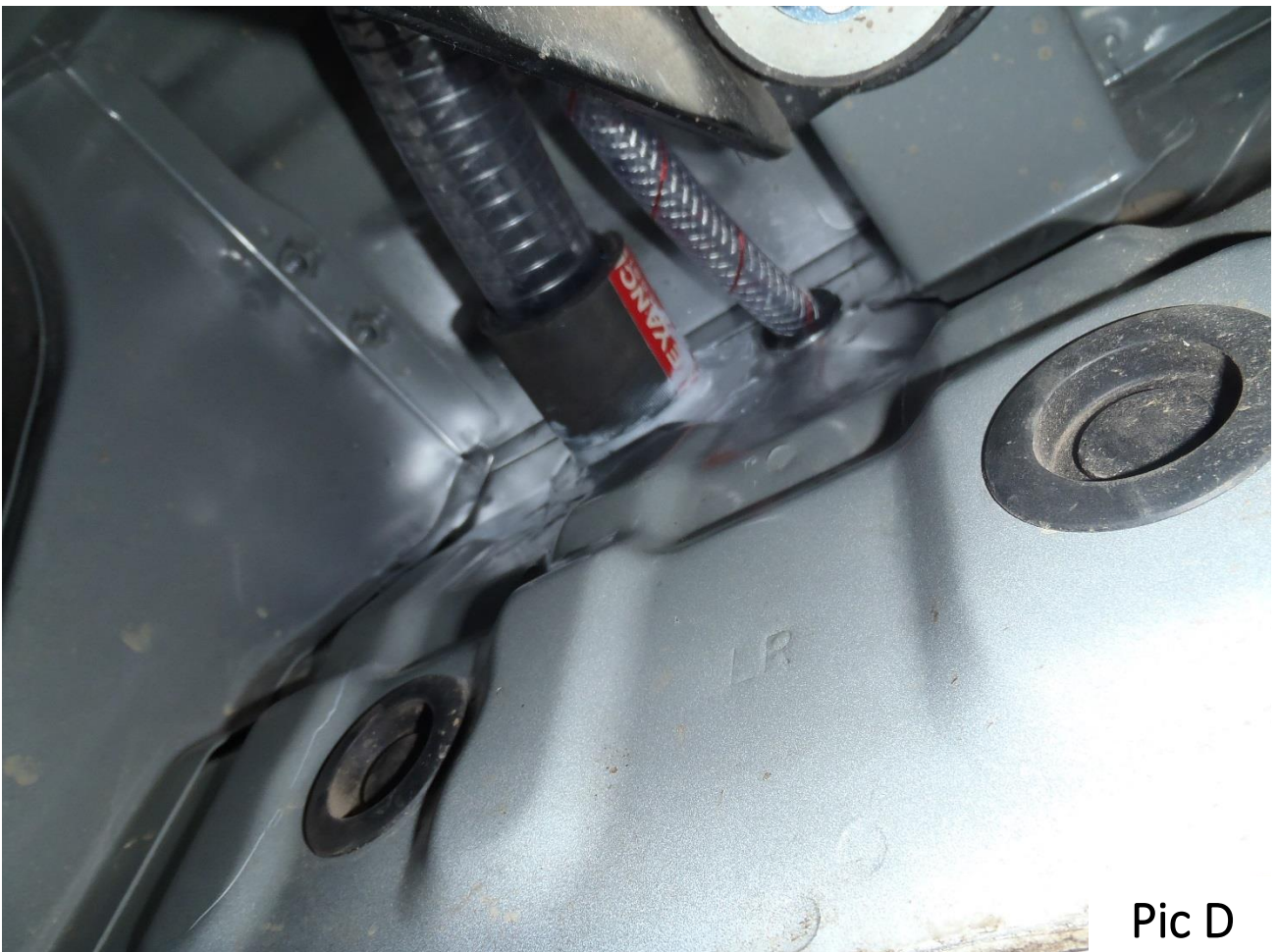

Pic D