



Installation Instructions for INEGRA-D Ineos Grenadier Diesel 68L Auxiliary Tank

This auxiliary fuel tank fits up under the rear of the vehicle, it has a capacity of 68Lt. The standard filler is replaced with a new twin filler neck. Fuel is transferred via an electric pump that will pump fuel from the auxiliary tank into the OEM tank. A combination switch/gauge will be located into a suitable position in the dash. When the switch is in operation an **ORANGE** light will be ON, indicating the transfer pump is in operation. A series of lights will also indicate fuel level. All **GREEN** lights on showing FULL, one **RED** flashing light showing EMPTY.

1. Remove the RHR wheel, wheel arch flare and wheel arch cover. Mount the switch gauge unit in a suitable location. (We suggest in the R/H corner of the dash facia 20mm down and 25mm across **(Refer Pic A)** A Factory fused 12-volt ignition source can be found in the R/H kick panel, it is taped back into the loom. Purple with a white trace and a black earth. These are controlled by one of the overhead aux power switches. **(Refer Pic B)** Complete wiring as per diagram and run the twin core cable to the rear of the vehicle under the scuff plates and exit out through the grommet in the R/H rear wheel arch. (Ref Pic C) For later connection to the pump and sender unit.
2. Remove the OE Muffler Shield and the rear section of the Heat Shield.
3. Fit the transfer pump to the mounting bracket and mount to crossmember with M8 x 20 bolt on strap. Drill a 8.5mm hole 40mm to the right of the OE hole. **(Refer Pic D + E)**
4. Cut the exhaust pipe where it enters the muffler, disconnect the mounts and remove the OE muffler. Cut the exhaust pipe @ 125mm as shown in photo **(Refer Pic F1 F2)** fit replacement exhaust pipe section and mount with the R/H OE muffler mount and M10 x 30mm bolt. Complete welding of exhaust pipe slip joint.
5. Replace the 4 x OE shield hanger bolts with M10 x 40mm Set Screw bolts. Fit the new L/H secondary bracket onto the hanger bracket studs with M10 spring and flat

washers and tighten. Repeat on the RHS but do not tighten for now. **(Refer Pic G + H)**

6. Cut the 16mm OE plastic line near the top of the OE filler and remove neck from vehicle. Cut the OE fill pipe 50mm from the bend **(Refer Pic I)** Clean up burrs and refit fill pipe to vehicle.
7. Assemble fittings into TFINEGRA-D Twin Filler **(Refer Drawing Fittings)**
8. Clip the Add Blue filler to the new Twin Filler and fit into position connecting to the OE fill pipe with 100mm of 32mm hose and clamps. Use P7 5/8 x 1/2 Reducing joiner to connect OE 16mm Fast Fill line to 16mm Elbow on top of twin filler with 100mm of 16mm hose and clamps. Connect the P10 0404 and brass screen from the top of the 6mm elbow on the twin filler with 6mm hose and point it down.
9. Use 950mm length of 8mm fuel hose to connect outlet of transfer pump to pump in port on the main tank branch of the twin filler.
10. Complete wiring of pump and run sender wire to the LHR corner for later connection.
11. Assemble fittings into the tank as per drawing. **(Refer Drawing Fittings)**
12. Begin to Jack the tank into position, once you have the tank brackets past the hanger brackets, connect the sender unit wire + earth and tighten the bolts on the RHS hanger and secondary bracket. Fix the tank with M8 x 30 bolts spring and flat washers + M10 x 30mm bolts washers and Nyloc nuts.
13. Connect the 1520mm length of 16mm hose to the aux tank and run over the crossmember following the main tank fill pipe up to the Twin filler and connect to the 16mm elbow on the Twin Filler. Connect the 780mm length of 8mm fuel hose to the fuel pick up on the aux tank and up to the inlet side of the pump. Cover with Conduflex.
14. Assemble the Aux tank fill pipe with pipes 1+2 and the three 90mm lengths of 32mm hose put it all together, check alignment and then tighten all clamps.
15. Neatly cable tie all hoses and wiring.
16. Ensure all clamps hoses etc are streamlined to allow the plastic wheel arch cover to fit neatly. Fit Cover and wheel arch flare.

17. Trim the exhaust shield as per **(Refer Drawing Heat Shield Cutting Guide)** and refit.



FITTING KIT CONTENTS INEGRA-D

| | |
|--|---|
| <p>Brass:</p> <ul style="list-style-type: none"> ○ 1 x P6 1/4 x 1/8 Elbow ○ 1 x P6 5/16 x 1/8 Elbow ○ 1 x P6 5/16 x 1/4 Elbow ○ 1 x P3 5/8 x 3/8 Straight ○ 2 x P6 5/8 x 3/8 Elbows ○ 1 x P7 5/8 x 1/2 Reducing Joiner ○ 1 x P10-0404 ○ 1 x 2921-04 1/4 Brass Screen ○ 1 x 025C-02 1/8 MxF Elbow | <p>Electrical:</p> <ul style="list-style-type: none"> ○ 1 x LRA PG-210 Switch Gauge ○ 1 x 3mm Two Core Wire @ 5000mm ○ 1 x Red Eye Terminals ○ 5 x 3mm Heat Shrink Tube @ 30mm ○ 1 x Red Insulated Terminal |
| <p>Bolts / Nuts:</p> <ul style="list-style-type: none"> ○ 2 x M8 x 30mm Bolts ○ 3 x M10 x 30mm Bolts ○ 4 x M10 x 40mm Set Screws ○ 1 x M8 Nyloc Nut ○ 3 x M10 Nyloc Nuts ○ 4 x M10 Nuts ○ 2 x M8 x Spring Washers ○ 4 x M10 Spring Washers ○ 1 x M8 x 20mm Washer ○ 2 x M8 x 25 Flat Washers ○ 14 M10 x 25mm Washers ○ 5 x M5 x 10 Pan Head Screws ○ 5 x M5 Spring Washers ○ 1 x M8 x 20mm Bolt on 150mm Strap ○ 1 x TEK Screw | <p>Misc Parts:</p> <ul style="list-style-type: none"> ○ 1 x FPINEGRA-D Fill Pipe ○ 1 x FBINEGRA-D Fill Bend ○ 1 x TFINEGRA-D Twin Filler ○ 1 x TFNL234D Fuel Cap Diesel Non Locking ○ 1 x L/H Secondary Bracket ○ 1 x R/H Secondary Bracket ○ 1 x EP-INEGRA-D Exhaust Tail Pipe |

| | |
|---|--|
| Hose Clamps: | Cable Ties: |
| <ul style="list-style-type: none"> ○ 4 x 1/4" Hose Clamps ○ 1 x 1/2" Hose Clamp ○ 4 x 5/8" Hose Clamps ○ 8 x 1 1/4" Hose Clamps ○ 2 x 1/4 Pinch Clamps | <ul style="list-style-type: none"> ○ 5 x 11" Cable Ties ○ 10 x 7" Cable Ties |
| Sender: | Pumps & Filters: |
| <ul style="list-style-type: none"> ○ 1 x 0-90 OHMS Sender Unit 500mm Earth Wire | <ul style="list-style-type: none"> ○ 1 x Fuel Transfer Pump ○ 1 x Fuel Pump Mounting Bracket |
| Hose: | 13 Pages of Fitting Instructions Consisting of: |
| <ul style="list-style-type: none"> ○ 1 x 6mm Fuel Hose @ 300mm ○ 1 x 8mm Fuel Hose @ 950mm ○ 1 x 8mm Fuel Hose @ 700mm ○ 1 x 32mm Hose @ 100mm ○ 3 x 32mm Hose @90mm ○ 1 x 16mm Fuel Hose @ 100mm ○ 1 x 16mm NTP Hose @ 1520mm ○ 1 x 16mm Conduflex @ 680mm | <ul style="list-style-type: none"> ○ 3 x Pages Fitting Instructions ○ 2 x Pages Fitting Kit Contents ○ 2 x Pages Reference Drawings ○ 5 x Pages Reference Pictures A-I ○ 1 x Page WDSGPG210 Diagram |

Kit Packed By _____

Checked By _____

INEGRA-D INSTRUCTION PHOTOS

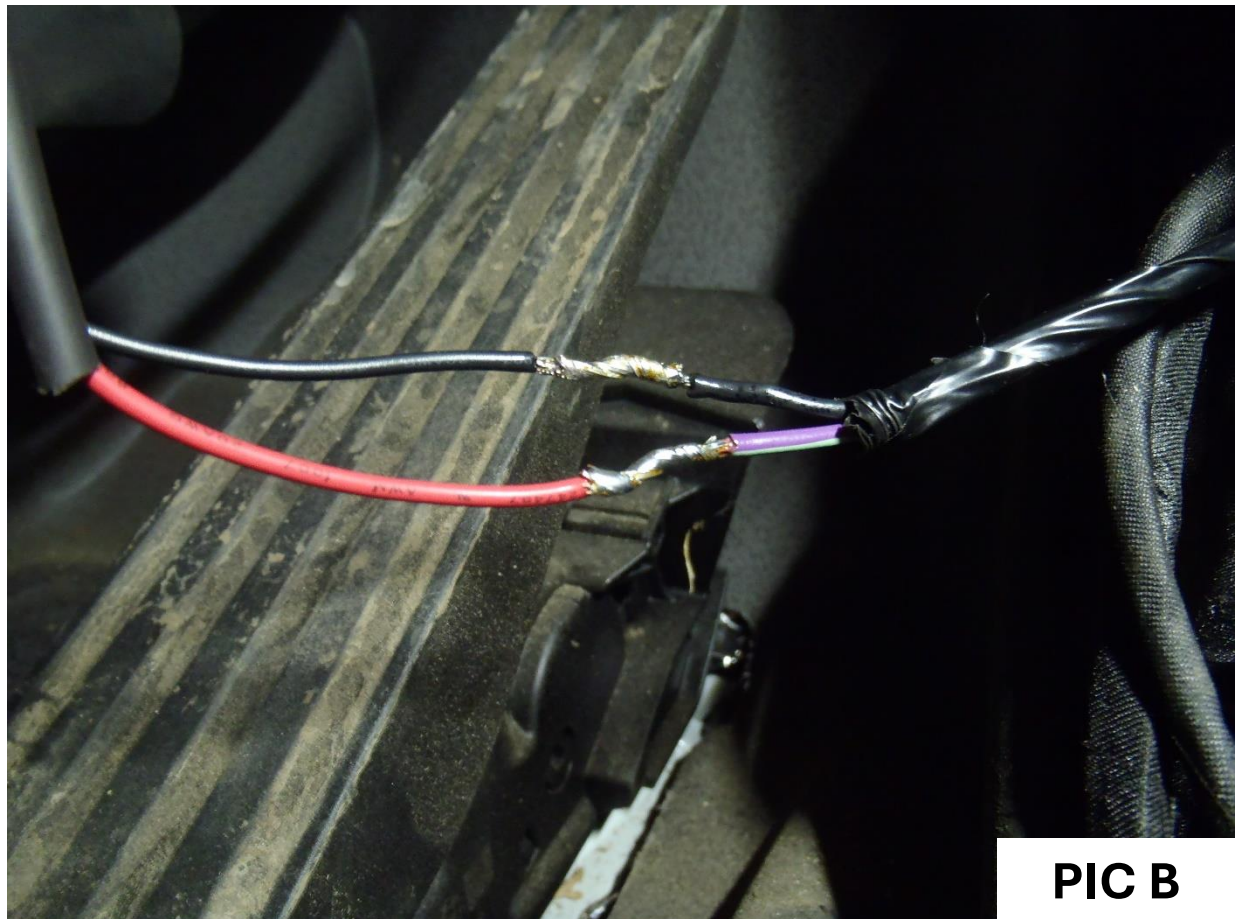
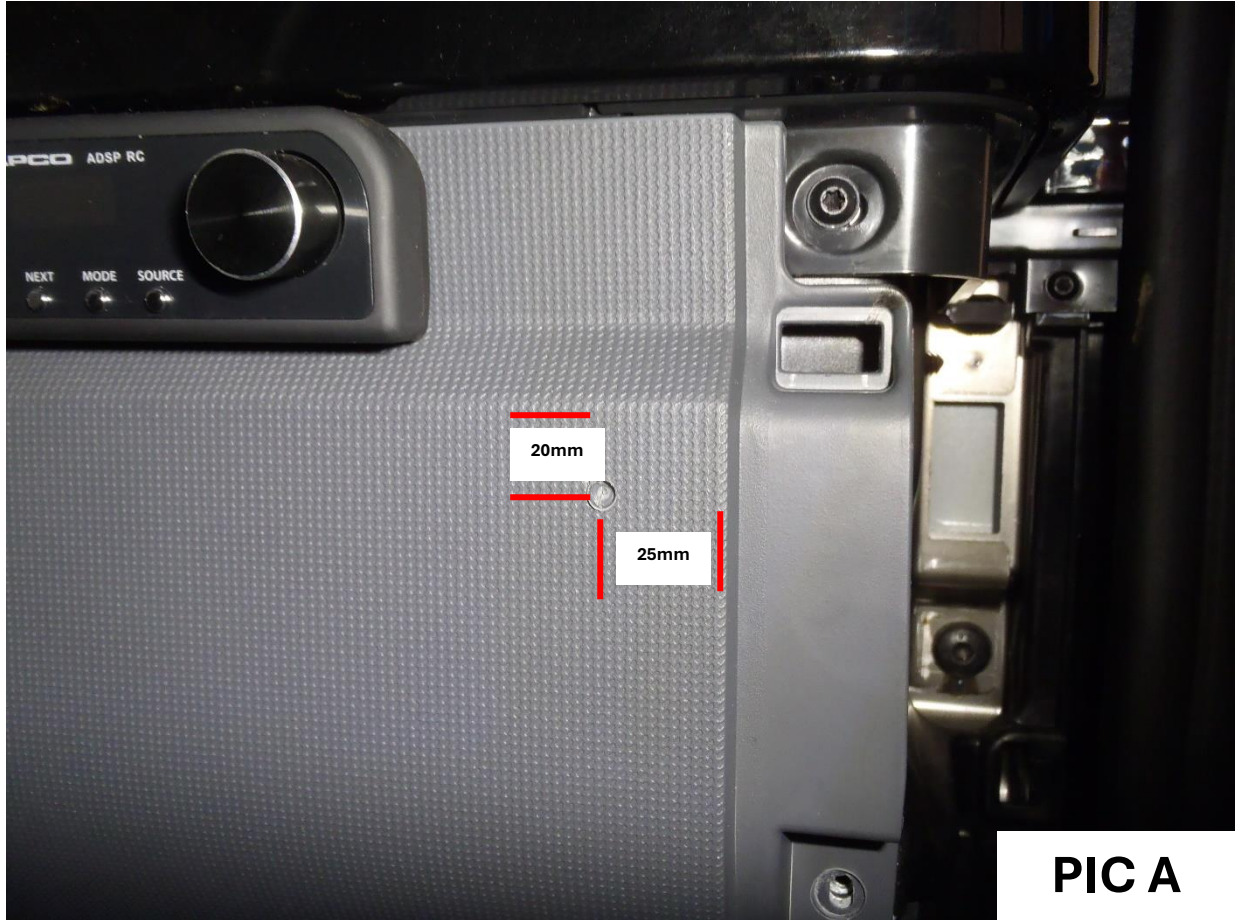

INEGRA-D INSTRUCTION PHOTOS



PIC C

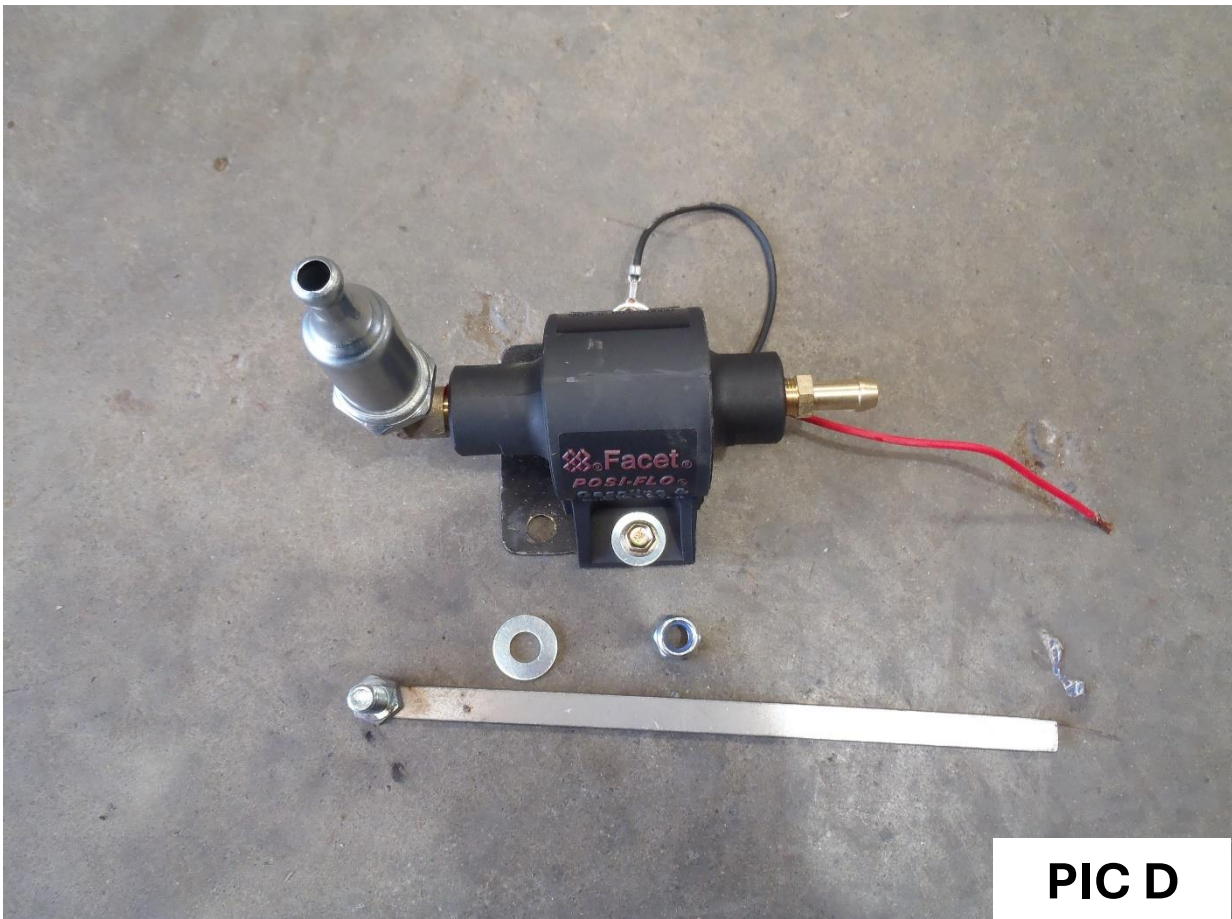

PIC D

INEGRA-D INSTRUCTION PHOTOS



PIC E



PIC F1

INEGRA-D INSTRUCTION PHOTOS



PIC F2

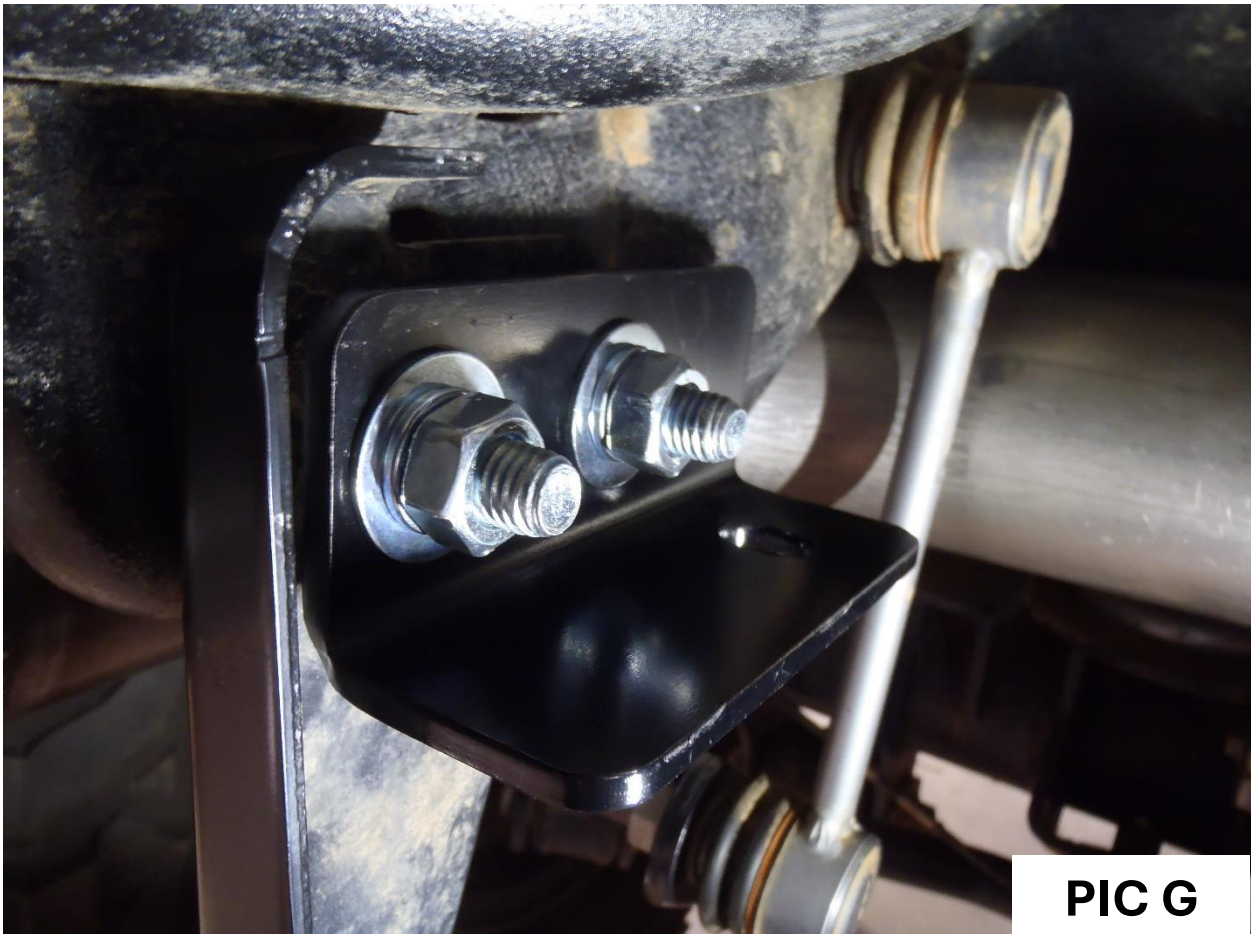

PIC G

INEGRA-D INSTRUCTION PHOTOS

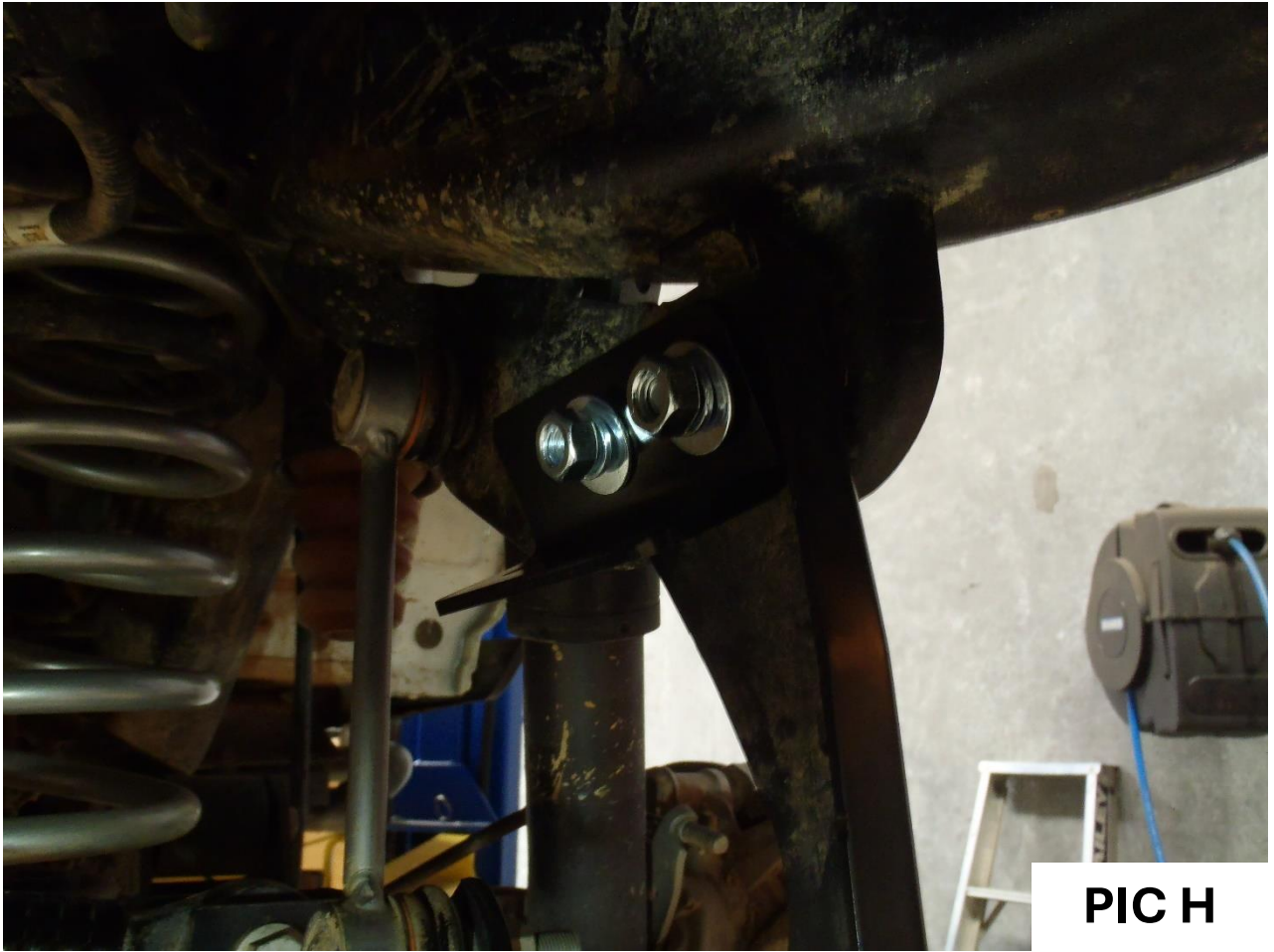

PIC H

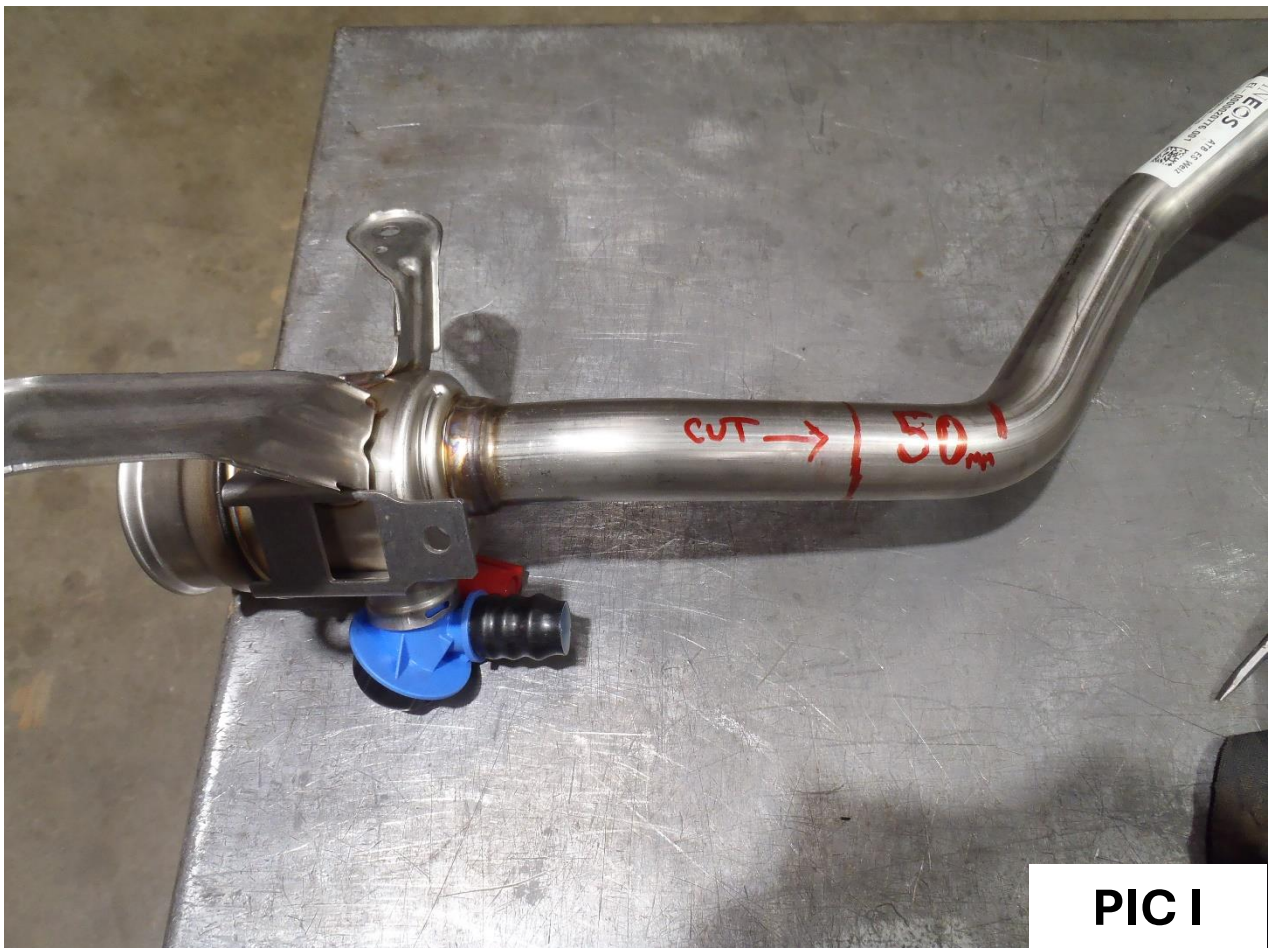

PIC I

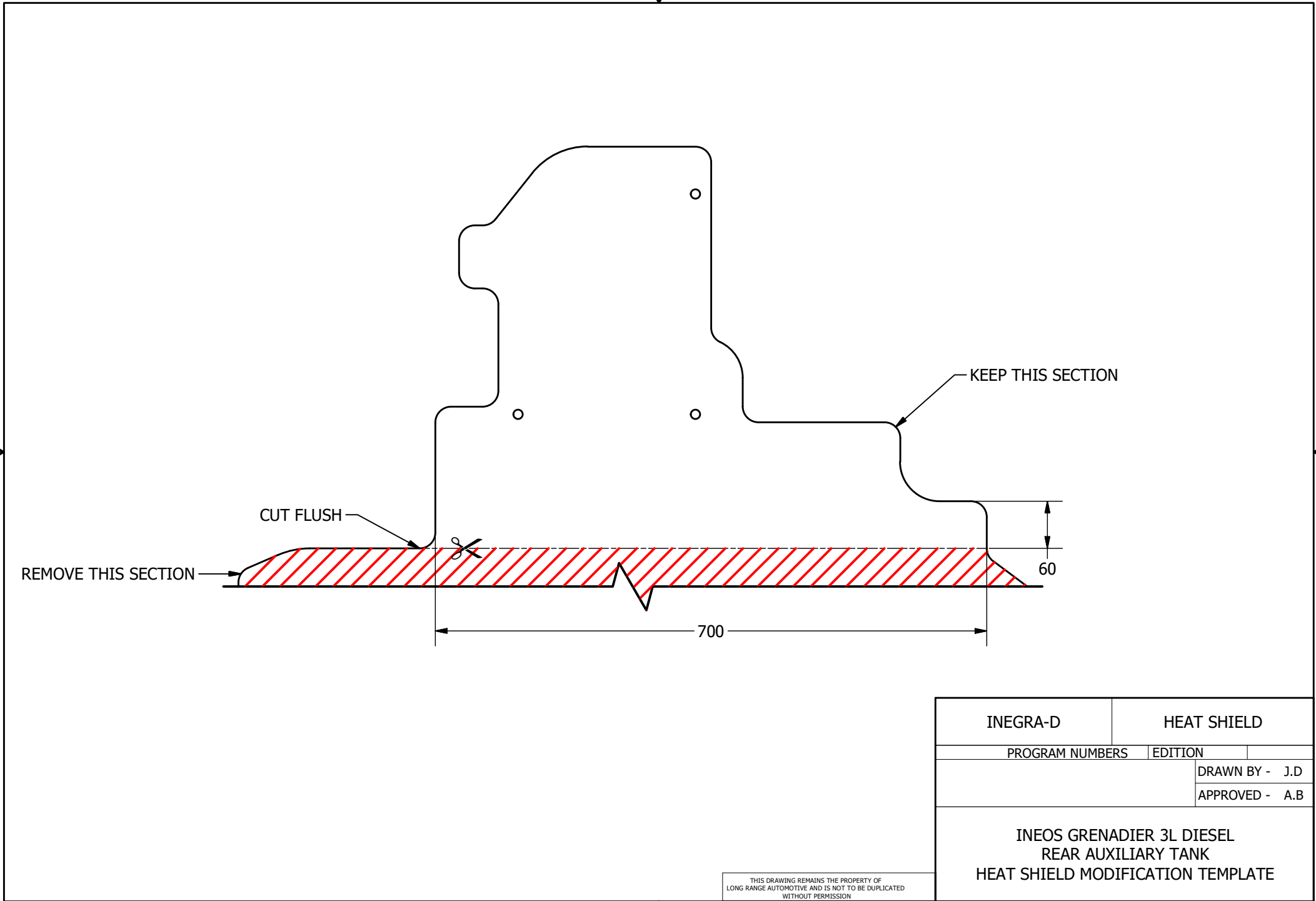

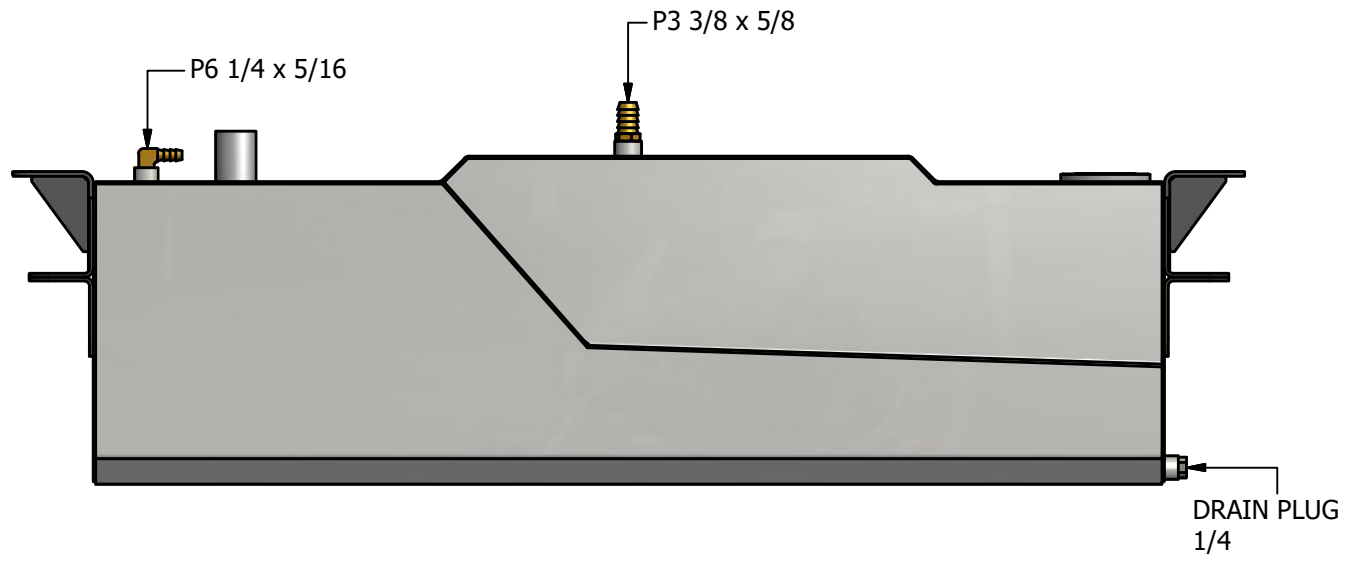
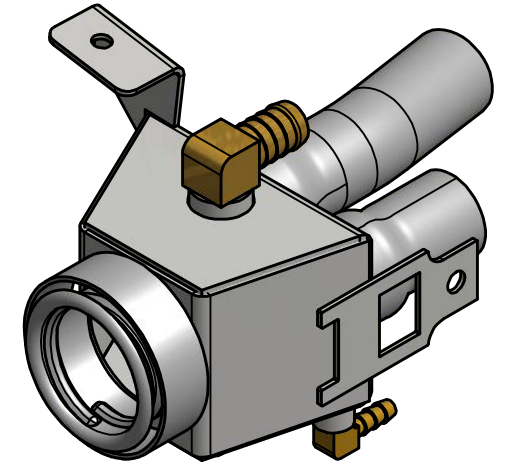
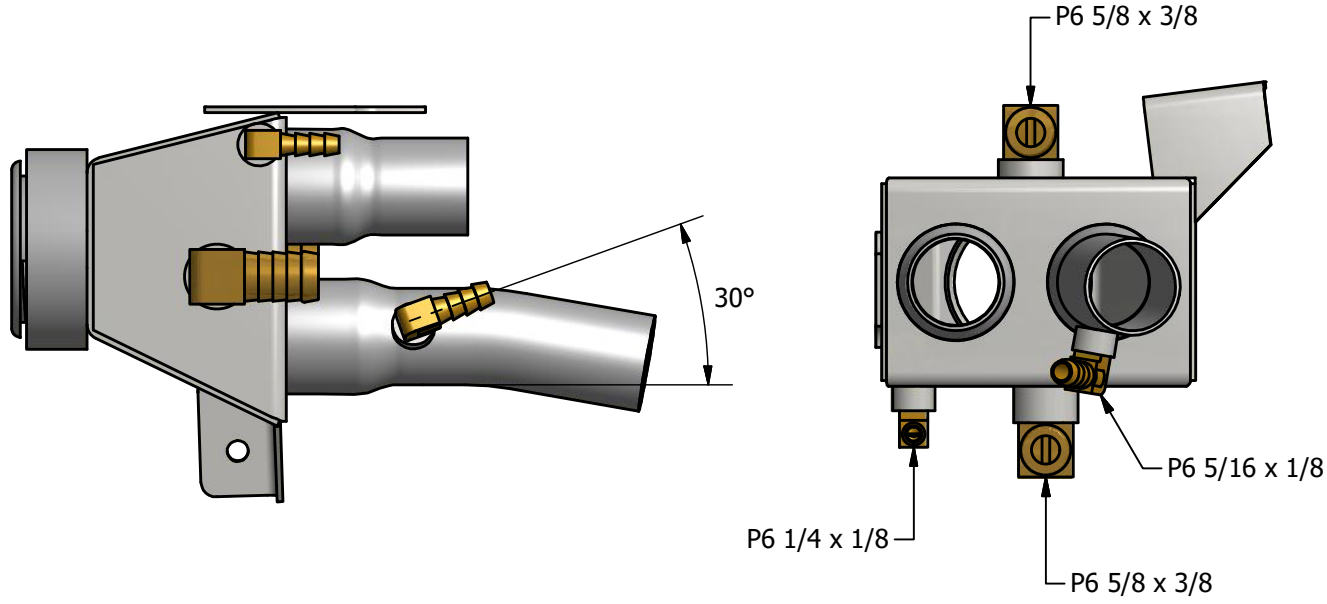

THIS DRAWING REMAINS THE PROPERTY OF
LONG RANGE AUTOMOTIVE AND IS NOT TO BE DUPLICATED
WITHOUT PERMISSION

| | | | |
|--|----------------------|---|----------------|
| TFINEGRA-D | TWIN FILLER FITTINGS | | |
| PROGRAM NUMBERS | EDITION | 1 | 14/08/2024 |
| - inegra-d04.CNC 2mm ALMS | | | DRAWN BY - J.D |
| | | | APPROVED - |
| INEOS GRENADIER 3L DIESEL REAR AUXILIARY TANK TWIN FILLER FITTINGS | | | |

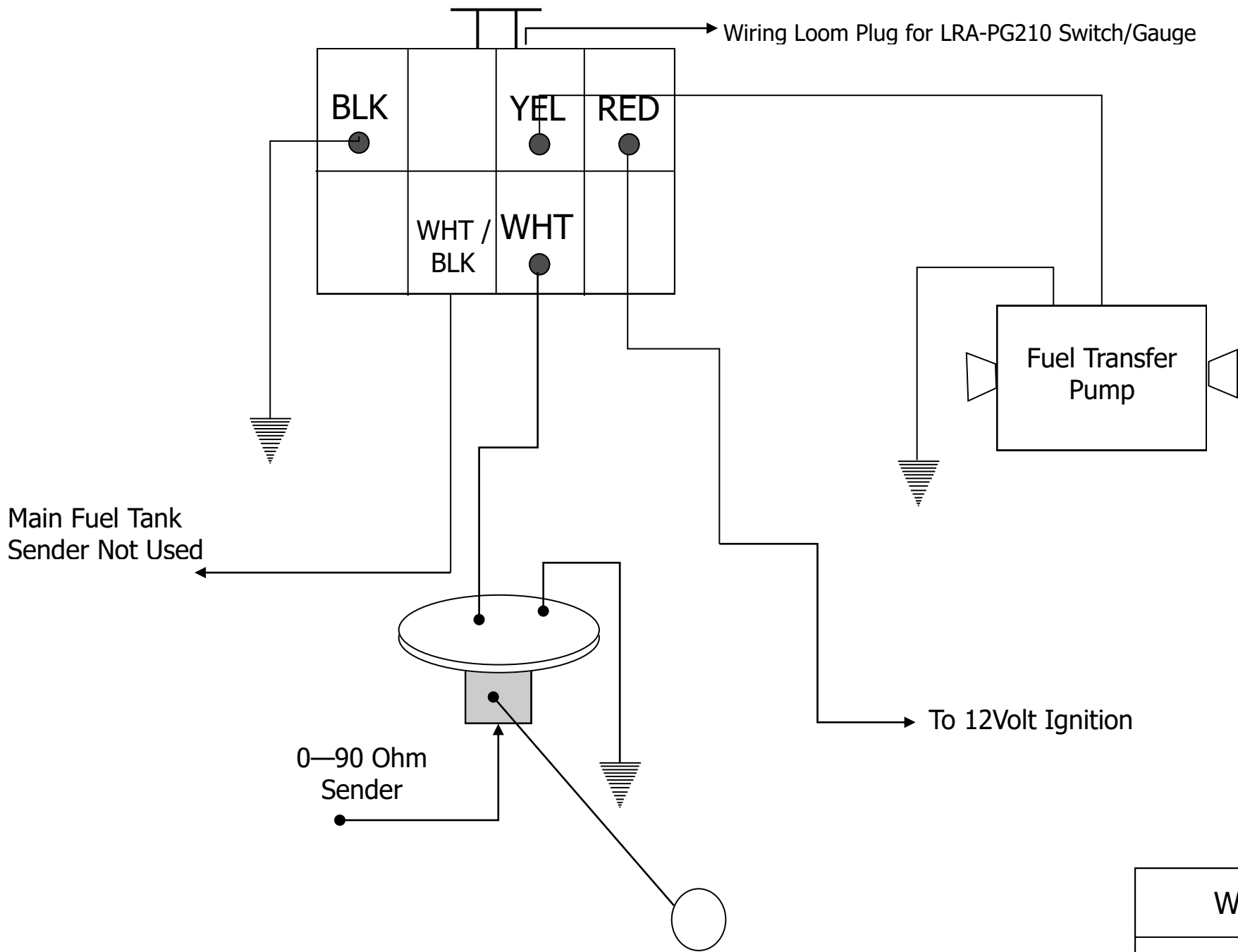

| |
|-----------|
| WDSGPG210 |
| |
| |