



Installation Instructions for NNDCRD40
Nissan Navara D40 Dual Cab
150L Replacement Tank

1. Disconnect filler and fast fill vent hoses from the tank and remove filler neck assembly from the vehicle. Disconnect the fuel pick-up and return lines, unclip tank vent line from LH chassis rail. Unbolt tank straps, lower the tank slightly and unplug the sender unit wiring. Remove the tank from the vehicle. Remove the stone shield from on top of the crossmember. (Not all vehicles have this fitted).
2. Modify rear tank locating strap hole as per drawing (needs to be made 36mm wide at the lower part of the slot). Cut filler neck and fast fill vent tube as per drawing.
3. Remove the fuel pick-up/sender assembly from original tank, unclip float arm from the unit and extend the horizontal section by 60mm (the rod provided in the kit is 80mm long to allow for 10mm overlap on each joint). Clip the float arm back into the assembly and check the full to empty OHM range. Refit to new tank with hold down ring, cap screws and new O-ring. Pick-up and return ports must point towards the LHS of the tank.
4. Carefully remove the bayonet couplings and fittings from the rigid plastic pick-up return and vent lines. Using the 750mm length of 8mm EFI hose for the pick-up and the 610mm length for the return and the original bayonet couplings, make up new fuel lines. (Bayonet coupling for the return line, at the steel line connection is a smaller fitting than the others). Clip these lines to the pick-up sender assembly with hoses pointing to the rear.
5. Use the vent line bayonet coupling and 6mm hose @ 750mm, for later connection to the P14 6mm tee. Fit the rubber grommet and roll over valve to the tank and use 6mm hose @ 160mm to connect to branch of P14 6mm tee. Use the remaining 400mm of 6mm hose to connect P14 6mm tee to vent line valve. (Take note of the direction on valve. It is marked 'Tank' on one end). With the short 50mm piece of 6mm hose, connect the vent line valve to the end stop that clips into the chassis rail.
6. Extend the sender unit wires by 200mm. We suggest cut solder and shrink tube. Use convoluted tubing over wiring.

7. Lock new rear strap in place and carefully bend down to allow the tank to be jacked into position, remembering to connect the sender unit wires and check that the pick-up and return lines point to the rear and then loop forward for later connection. Jack tank into position and secure rear strap with original bolt. To fit the front strap, bolt in board mount with reinforcing plate; finger tight only, then with the tank in position use the small hole next to the outside mount to line up the bolt hole in the strap. Bolt in place. (Be careful not to cross thread). Check tank clearances and tighten all mounting bolts.
8. Run the 6mm hose from the sender/pick-up vent over the crossmember and connect to the tee from the top rear roll over valve. Vent line end stop can now be clipped back into the chassis rail. Cable tie to top rear of the tank with adhesive tie mount and fix line to body brace with rubber lined P clip and TEK screw.
9. From the original fill hose, cut 110mm from the long end and 45mm from the short end. Refit previously modified filler neck to the vehicle with this hose and the STD fast fill vent hose. (Long end goes to filler neck, short end goes to tank).
10. Connect pick up and return lines. Check for clearances and fix to body with 2 x rubber lined P clips and TEK screws.
11. Remove heat shield from STD tank and refit to the new tank using original clips.
12. Fill with fuel and check all hoses and fittings.



FITTING KIT CONTENTS NNDCRD40

Brass:	Electrical:
<ul style="list-style-type: none"> ○ 1 x P14 1/4 Tee 	<ul style="list-style-type: none"> ○ 1 x 3mm Single Core Yellow @ 200mm ○ 1 x 3mm Single Core Black @ 200mm ○ 4 x Heat Shrink Tube @ 30mm
Bolts / Nuts:	Misc Parts:
<ul style="list-style-type: none"> ○ 6 x M5 x 8mm Cap Screws ○ 6 x M5 Washers ○ 2 x TEK Screws 	<ul style="list-style-type: none"> ○ 1 x 6mm Rubber Line P Clip ○ 2 x 8mm Rubber Line P Clip ○ 1 x Conduflex – 7 @ 200mm ○ 1 x Hold Down Ring ○ 1 x 3mm Rubber 65 x 300 ○ 1 x 3mm Rubber 65 x 330 ○ 1 x BS356 O-Ring ○ 2 x Strap Reinforcing Plates ○ 1 x Pair Tank Straps ○ 1 x 50mm Tank Strap Rubber @ 440mm ○ 1 x 50mm Tank Strap Rubber @ 800mm ○ 1 x Adhesive Cable Tie Mount ○ 1 x LRA-FTG-2 Grommet ○ 1 x FV11 Roll Over Valve
Hose Clamps:	Cable Ties:
<ul style="list-style-type: none"> ○ 11 x EFI Hose Clamps 	<ul style="list-style-type: none"> ○ 1 x 7" Cable Tie
Sender:	Pumps & Filters:
<ul style="list-style-type: none"> ○ 1 x 2.5 Rod @ 80mm 	
Hose:	5 Pages of Fitting Instructions Consisting of:
<ul style="list-style-type: none"> ○ 1 x 6mm Hose @ 50mm ○ 1 x 6mm Hose @ 160mm ○ 1 x 6mm Hose @ 400mm ○ 1 x 6mm Hose @ 750mm ○ 1 x 8mm EFI Hose @ 610mm ○ 1 x 8mm EFI Hose @ 750mm 	<ul style="list-style-type: none"> ○ 2 x Pages Fitting Instructions ○ 1 x Page Fitting Kit Contents ○ 1 x Page Filler Modification Diagram ○ 1 x Page Tank Strap Modification Diagram

Kit Packed By _____

Checked By _____

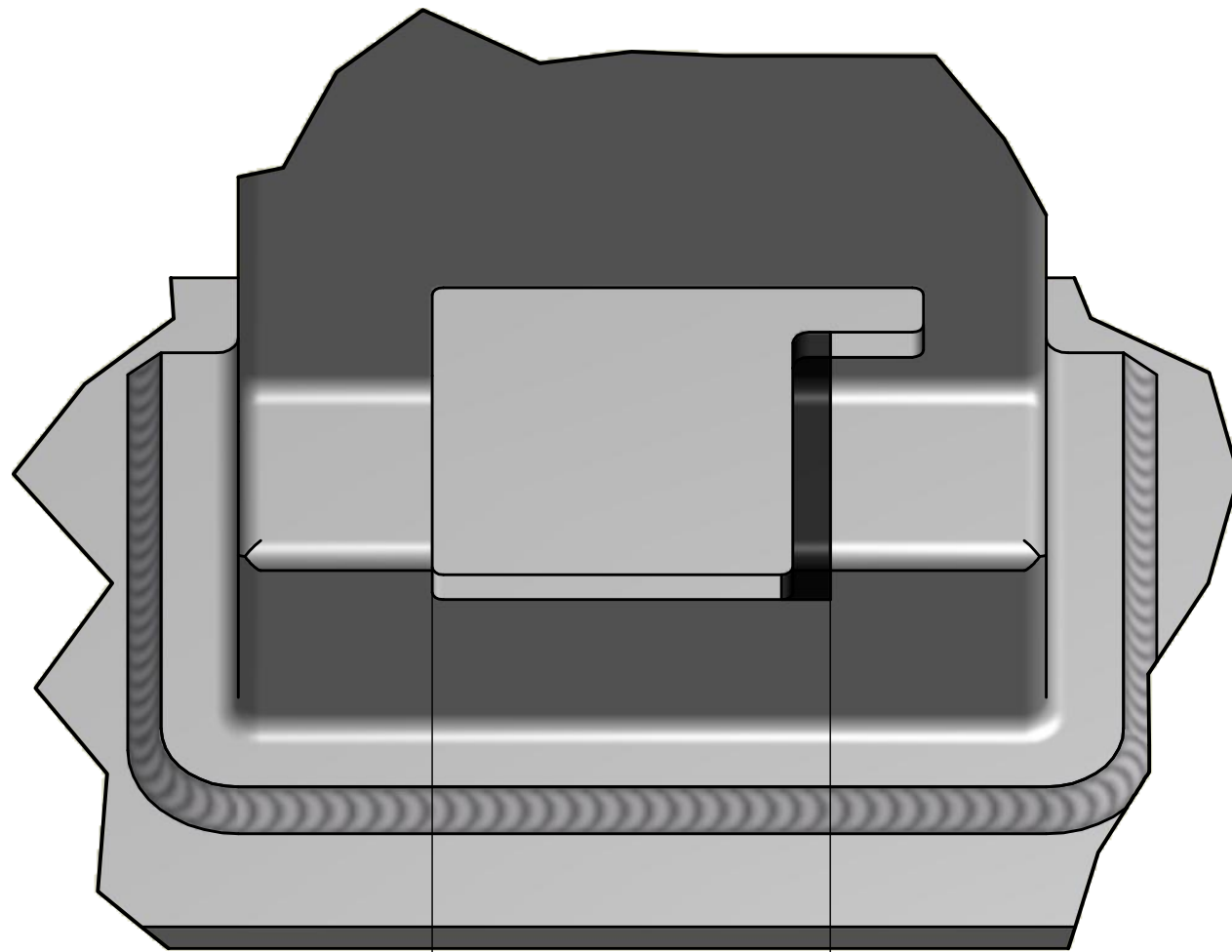

36mm

THIS DRAWING REMAINS THE PROPERTY OF
LONGRANGE AUTOMOTIVE AND IS NOT TO BE DUPLICATED
WITHOUT PERMISSION



NNDCRD40	INSTALL
Nissan Navara D40 dual cab 2005- 150ltr replacement tank. Tank strap cut-out modification	

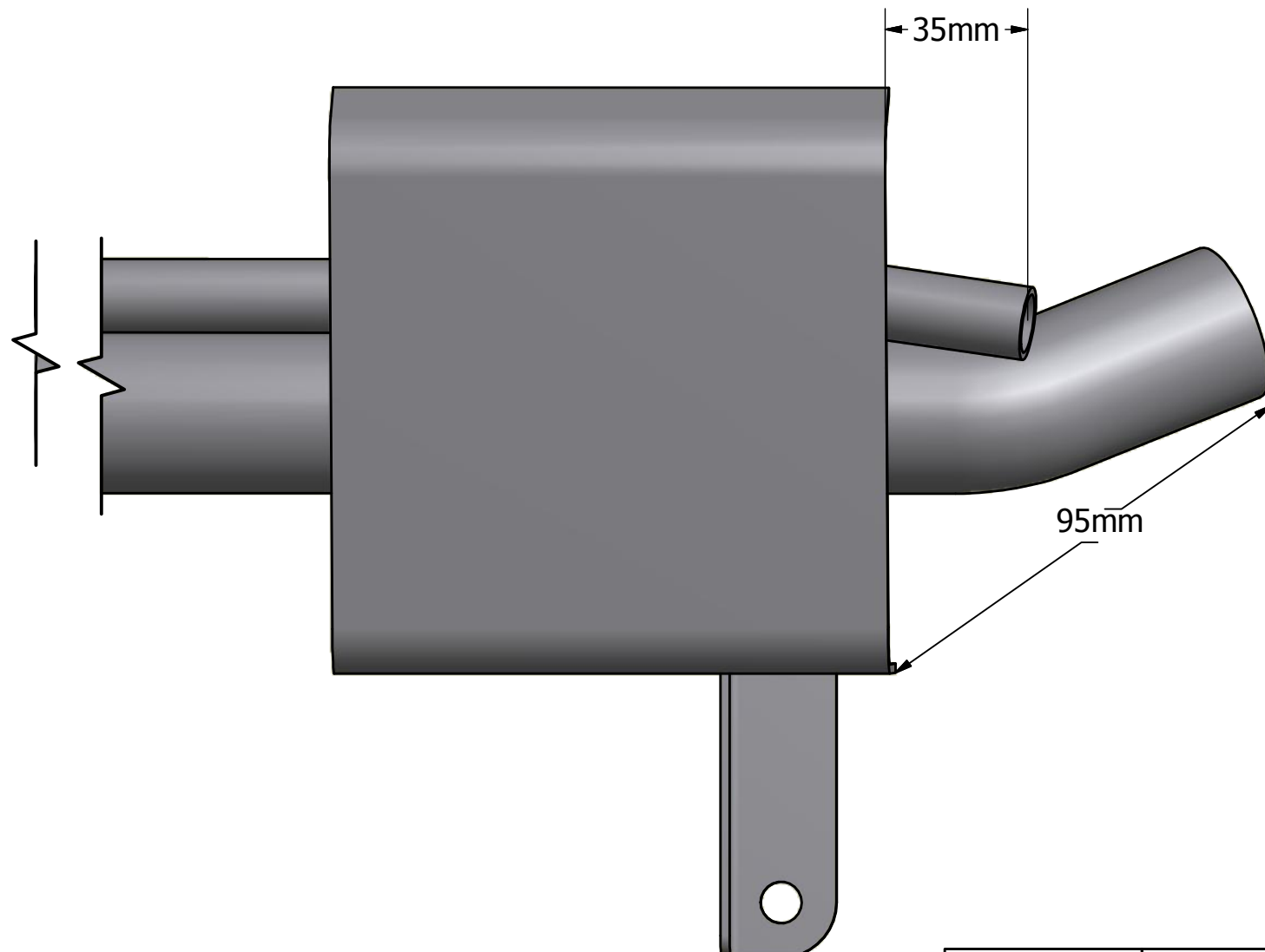

THIS DRAWING REMAINS THE PROPERTY OF
LONGRANGE AUTOMOTIVE AND IS NOT TO BE DUPLICATED
WITHOUT PERMISSION



NNDCRD40

INSTALL-2

Nissan Navara D40 dual cab 2005-
150ltr replacement tank.
Filler modifications